



Pika X3001 Grid-tie Inverter

Operation Manual



www.pika-energy.com

Operation Manual for the X3001 Bidirectional REbus™ Inverter

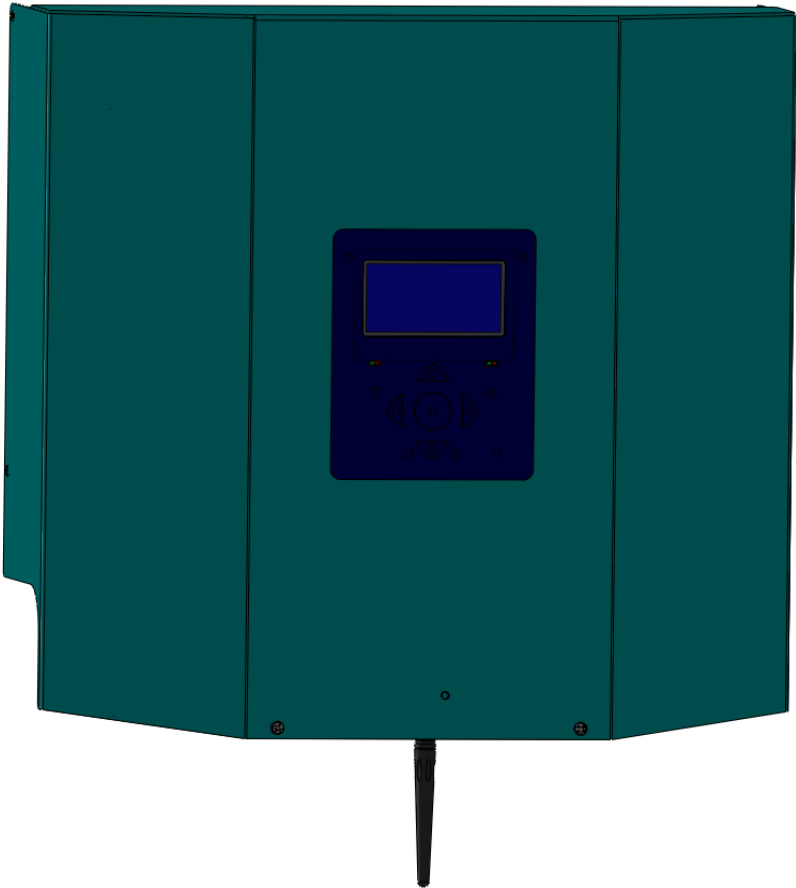

Revision Table

Revision	Date	Changes
1.0	2012-06-25	Initial Release
1.1	2012-09-17	Changes from UL1741 and CSA review
1.2	2012-11-10	Changes for Intertek listing report
1.3	2014-01-01	Updates for Gamma build

General Remarks

Congratulations! You have purchased the Pika Energy X3001 REbus™ bidirectional DC/AC inverter, a dependable, efficient component of your clean energy system. The X3001 is the result of the Pika team's careful development and testing, building on decades of experience in the fields of power electronics and renewable energy systems.

The X3001 is an electrically non-isolated single-stage inverter designed for high-efficiency bidirectional conversion between a REbus™ Microgrid and 220-240 VAC 60 Hz split-phase utility service. This inverter is passively cooled for high reliability and low noise. A replaceable capacitor bank ensures that even in the unusual event of capacitor failure, an easy remedy is available. An illuminated display and intuitive system of menus enable you to display the energy output of every component of your renewable energy system, including the energy exported by the inverter to the grid. The inverter also serves as an information gateway, enabling monitoring and control of your entire renewable energy system.

Unlike conventional inverters, which only connect to one type of energy source, Pika's X3001 is designed to operate as the hub for an expandable network of renewable energy devices, based on the REbus™ renewable energy standard.

What is REbus™?

The underlying technology behind Pika Energy's X3001 Inverter is an innovative energy management technology or 'smart microgrid' called REbus™. REbus™ is a DC energy network that operates alongside the existing AC infrastructure, enabling customers to build cost-effective, scalable renewable energy systems. The REbus™ network is designed to serve as an open interconnection standard for networking next-generation energy technology – like Wi-Fi or USB for green energy!

IMPORTANT! Only REbus™ compatible components may be used in connection with this inverter. Do not connect the output of a PV array or any other non-REbus™ electrical source to the inverter terminals- serious property damage and/or personal injury may result.

Contents

Revision Table	1
General Remarks.....	2
1 Regarding this Document.....	5
1.1 Symbols used in this document	5
1.2 Standards	5
1.3 Data Label	5
2 Important safety information and instructions	6
2.1 Appropriate Usage	6
2.2 AC Output Details.....	6
3 Notes concerning installation and operation	7
3.1 Intended (normal) use	7
3.2 Pika Energy Factory Limited Warranty.....	7
3.3 Service	9
4 The REbus™ Microgrid.....	10
4.1 Simple and Efficient Power Distribution and Management	10
4.2 Integrated Power Line Carrier (PLC) Communications	10
4.3 REbus™ Control Protocol (RCP).....	10
5 Designing a REbus™ System.....	11
6 Operation	12
6.1 Installation	12
6.2 Power Switch	12
6.3 Enable/Disable	12
6.4 Power Outage	12
6.5 High Temperature Operation.....	12
7. User Interface.....	13
7.1 Overview of User Interface	13
7.2 LED Displays	13
7.2.1 Multicolor “REbus” LED.....	13
7.2.2 Multicolor “Grid” LED.....	13
7.2.3 Blue “Wi-Fi” LED.....	13

7.3 LCD Display.....	13
7.3.1 REbus™ System Page.....	13
7.3.2 X3001 Inverter Page.....	15
7.3.3 Wi-Fi Status Page	16
7.3.4 Other REbus Device Pages	17
7.3.5 Background Illumination	18
7.4 Navigating the Menus	18
8 Internet Compatibility.....	18
8.1 Wi-Fi Antenna	19
8.2 Configuring your Wi-Fi Connection.....	19
8.2.1 Scan-based network setup.....	19
8.2.2 Manual configuration network setup	20
8.3 Wi-Fi Status Messages and Troubleshooting.....	21
8.3.1 Connection states:	21
8.3.2 Connection state messages:	22
8.4 Pika account and the REview™ online monitoring system	23
9 Maintenance	24
9.1 Replaceable Capacitor Bank.....	24
10 Troubleshooting.....	24
11 Frequently Asked Questions	25
11.1 Why is there only one question in the FAQ?	25
12 Specifications	26

1 Regarding this Document

This manual contains important instructions for the X3001 Inverter that must be followed during installation and maintenance of the inverter. The X3001 is designed and tested according to international safety requirements, but as with all electrical and electronic equipment, certain precautions must be observed when installing and/or operating the X3001. To reduce the risk of personal injury and to ensure the safe installation and operation of the X3001, you must carefully read and follow all instructions, cautions and warnings in this user manual.

Store this manual so that it is always easily accessible.

1.1 Symbols used in this document



WARNING: This indicates a fact or feature very important for the safety of the user to prevent injury or death and/or which can cause serious hardware damage if not applied appropriately.



CAUTION: Presents information to prevent damage to this product



EARTH GROUND SYMBOL

1.2 Standards

The Pika X3001 Inverter is certified by Intertek to be compliant with the UL 1741/IEEE 1547 standards as they apply to utility-interactive inverters.

1.3 Data Label

A permanently affixed label indicating the device specifications, serial number, and manufacturing date is located on the bottom surface of the inverter enclosure. Tampering with label can void warranty.

2 Important safety information and instructions

IMPORTANT SAFETY INSTRUCTIONS

SAVE THESE INSTRUCTIONS

This manual contains important instructions for model X3001 that shall be followed during installation and maintenance of the Pika X3001 Inverter.



WARNING: Before installing the Pika Energy X3001 Inverter, read all instructions and caution markings in this manual and on the X3001 as well as on other REbus™ devices.



WARNING: Electrical installation in the United States shall be done in accordance with all local electrical codes and/or the National Electrical Code (NEC), ANSI/NFPA 70.



WARNING: Electrical installation in Canada shall be done in accordance with all local electrical codes and/or the Canadian Electrical Code.



WARNING: Connecting the X3001 to the electric utility grid must only be done after receiving prior approval from the utility company and installation completed only by qualified personnel/licensed electrician(s).

2.1 Appropriate Usage

The X3001 is an electrically non-isolated single-stage inverter designed for high-efficiency bidirectional conversion between a REbus™ Microgrid and a 220-240 VAC split-phase utility. Refer to the inverter installation guide for detailed information about the product and its intended use. The inverter may only be operated with REbus™ devices. Do not use the inverter for purposes other than those described here. Alternative uses, modifications to the inverter or the installation of components not expressly recommended or sold by the manufacturer void the warranty claims and operating permission. Contact the Pika Energy technical support if you need clarification regarding proper use of the inverter.

2.2 AC Output Details

The X3001 is to be connected to a split-phase 220-240VAC utility only. This means 120VAC from line to neutral and 240VAC from line to line. The AC neutral is not bonded to ground in the inverter. It is the responsibility of the installer to bond neutral to ground externally. The input and output circuits are isolated from the enclosure. System grounding to the ground lugs provided in the wiring box is the responsibility of the installer.

3 Notes concerning installation and operation

3.1 Intended (normal) use

Your inverter is strictly constructed according to approved safety requirements. Improper use may lead to lethal hazards for operators and/or damage to devices and property. The X3001 is certified to comply with the UL 1741 standard for utility-interactive devices, and includes important safety features. The 'anti-islanding' safety feature shuts down the inverter in the event of a grid power failure to avoid back-feeding power during a grid outage, which could result in injury to utility repair personnel. Improper use or modification of the X3001 may result in serious property damage, personal injury or death.

REBUS™ INPUT ONLY! The X3001 is designed to accept regulated direct current (DC) from REbus-compatible devices (e.g. REbus-compatible wind turbine, REbus-compatible PV Link unit) into grid-compatible alternating current (AC). DO NOT CONNECT PHOTOVOLTAIC MODULES DIRECTLY TO THE REBUS™ INPUTS OF THE X3001 INVERTER. DOING SO WILL VOID THE WARRANTY AND MAY DAMAGE THE INVERTER.

The X3001 must only be operated in conjunction with a fixed connection to the utility grid and is not intended for off-grid or mobile use. This unit is provided with fixed trip limits and shall not be aggregated above 30 kW on a single Point of Common Connection.

Any use other than the specified intended use shall not be deemed intended or normal use, and may result in property damage, personal injury or death. Pika is not liable for damage or injuries caused by unintended use.

Damage caused by unintended use is at the sole risk of the operator.

"Intended use" shall also include adherence to the operating and installation instructions.

Your trained and authorized installer must obtain all necessary permits and agreements from your local government and your utility company for a legal and code-compliant installation of your REbus™ Microgrid system. See the Installation Manual for more detail.

3.2 Pika Energy Factory Limited Warranty

Pika Energy LLC ("Pika") has developed a reliable, efficient inverter, designated X3001 ("Inverter"), that is designed to withstand normal operating conditions when used in accordance with its intended use and in compliance with instructions in the accompanying Installation Manual and User Manual shipped with the unit. The Pika limited warranty ("Limited Warranty") covers defects in workmanship and materials of the Pika Inverter ("Defective Product") for a period of five (5) years from the date of original purchase of such Inverter at point of sale to the originally-installed end user location (the "Warranty Period"). During the Warranty Period, the warranty is transferable to a different owner as long as the Inverter remains installed at the originally-installed end user location.

During the Warranty Period, if Pika determines through inspection the existence of a defect that is covered by the Limited Warranty, Pika will at its option, either (1) repair or replace the Defective Product free of charge, or (2) provide a credit or refund to the owner of the system at the originally installed end user location in an amount not to exceed the then-current price of (a) a “like kind” inverter that is available for purchase by the system owner at the time of the Limited Warranty claim, or (b) the original cost of the Pika Inverter that is subject to a Limited Warranty claim.

If Pika elects to repair or replace the Defective Product, Pika will, at its option, use new and/or reconditioned parts in repairing or replacing the Defective Product. Pika reserves the right to use parts or products of original or improved design in the repair or replacement of Defective Product. If Pika repairs or replaces a Defective Product, the Limited Warranty continues on the repaired or replacement product for the remainder of the original Warranty Period or ninety (90) days from the date of Pika’s return shipment of the repaired or replacement product, whichever is later. The Limited Warranty covers both parts and labor necessary to repair the Defective Product (if Pika elects to repair the Defective Product), but does not include labor costs related to (i) un-installing the Defective Product or (ii) if applicable, re-installing a repaired or replacement product. To the extent applicable, the Limited Warranty also covers the costs of shipping a repaired or replacement product from Pika, via a non-expedited freight carrier selected by Pika, to locations within the United States (including Alaska and Hawaii) and Canada, but not to other locations outside the United States or Canada. The Limited Warranty does not cover, and Pika will not be responsible for, shipping damage or damage caused by mishandling by the freight carrier and any such damage is the responsibility of the freight carrier.

To obtain repair or replacement service, credit or refund (as applicable) under this Limited Warranty, the customer must comply with the following policy and procedure:

- Many problems can be addressed in the field. Prior to returning a product, customer must contact Pika technical support to evaluate and troubleshoot the problem in the original installation setting.
- All Defective Product must be returned with a Return Merchandise Authorization Number (RMA) which customer must request from Pika.
- Requests for RMA must include the following information:
 - Proof-of-purchase of the Defective Product in the form of (1) the dated purchase receipt from the original purchase of the product at point of sale to the end user, or (2) the dated dealer invoice or purchase receipt showing original equipment manufacturer (OEM) status, or (3) the dated invoice or purchase receipt showing the product exchanged under warranty
 - Model number of the Defective Product
 - Serial number of the Defective Product
 - Detailed description of the defect.
 - Shipping address for return of the repaired or replacement product (as applicable).
- All Defective Product authorized for return must be returned in the original shipping container or other packaging that is equally protective of the product.
- The returned Defective Product must not have been disassembled or modified without the prior written authorization of Pika.

Pika Inverters are designed to withstand normal operating conditions and typical wear and tear when used for their original intent and in compliance with the installation and operating instructions supplied with the original equipment. The Limited Warranty does not apply to, and Pika will not be responsible

for, any defect in or damage to any Pika inverter: (1) that has been misused, neglected, tampered with, altered, or otherwise damaged, either internally or externally; (2) that has been improperly installed, operated, handled or used, including use under conditions for which the product was not designed, use in an unsuitable environment, or use in a manner contrary to the Pika User Manual or applicable laws or regulations; (3) that has been subjected to fire, water, generalized corrosion, biological infestations, acts of God, or input voltage that creates operating conditions beyond the maximum or minimum limits listed in the Pika Inverter specifications, including high input voltage from generators or lightning strikes; (4) that has been subjected to incidental or consequential damage caused by defects of other components of the system; or (5) if the original identification markings (including trademark or serial number) of such Inverter have been defaced, altered, or removed. The Limited Warranty does not cover costs related to the removal, installation or troubleshooting of the customer's electrical systems. The Limited Warranty does not extend beyond the original cost of the Pika Inverter.

THE LIMITED WARRANTY IS THE SOLE AND EXCLUSIVE WARRANTY GIVEN BY PIKA AND, WHERE PERMITTED BY LAW, IS MADE EXPRESSLY IN LIEU OF ALL OTHER WARRANTIES, EXPRESS OR IMPLIED, STATUTORY OR OTHERWISE, INCLUDING, WITHOUT LIMITATION, WARRANTIES OF TITLE, QUALITY, MERCHANTABILITY, FITNESS FOR A PARTICULAR PURPOSE OR NONINFRINGEMENT OR WARRANTIES AS TO THE ACCURACY, SUFFICIENCY OR SUITABILITY OF ANY TECHNICAL OR OTHER INFORMATION PROVIDED IN MANUALS OR OTHER DOCUMENTATION. IN NO EVENT WILL PIKA BE LIABLE FOR ANY SPECIAL, DIRECT, INDIRECT, INCIDENTAL OR CONSEQUENTIAL DAMAGES, LOSSES, COSTS OR EXPENSES HOWEVER ARISING, WHETHER IN CONTRACT OR TORT, INCLUDING WITHOUT LIMITATION ANY ECONOMIC LOSSES OF ANY KIND, ANY LOSS OR DAMAGE TO PROPERTY, OR ANY PERSONAL INJURY.

To the extent any implied warranties are required under applicable law to apply to the Pika Inverter, such implied warranties shall be limited in duration to the Warranty Period, to the extent permitted by applicable law. Some states and provinces do not allow limitations or exclusions on implied warranties or on the duration of an implied warranty or on the limitation or exclusion of incidental or consequential damages, so the above limitation(s) or exclusion(s) may not apply. This Limited Warranty gives the customer specific legal rights, and the customer may have other rights that may vary from state to state or province to province.

3.3 Service

WARNING: Do not attempt to repair the X3001 Inverter. The inverter contains no user-serviceable parts.

If the Pika X3001 Inverter fails, first contact Pika customer service at (207) 887-9105 for troubleshooting help. See the Warranty section for details on terms and conditions for repair or replacement under warranty. You must obtain an RMA (Returned Merchandise Authorization) number prior to returning the unit. Obtain the assistance of a skilled and qualified installer to safely disconnect the inverter for shipment.

Technical Support Information:

- Support department hours: 9AM to 5PM Eastern Standard Time Zone, Monday – Friday (excluding holidays)
- Phone: (207) 887-9105
- Email: support@pika-energy.com

4 The REbus™ Microgrid

The REbus™ Microgrid is the underlying technology that allows for the efficient and robust interconnection of different types of renewable energy products. This section is informational only and not required knowledge for operation of your Pika X3001 Inverter.

4.1 Simple and Efficient Power Distribution and Management

The REbus™ Microgrid architecture was designed with renewable energy in mind. A clean-sheet approach to power distribution resulted in the most practical and efficient interconnection technology available. The microgrid operates at variable voltage in a defined band, between +/- 180-200 V relative to ground which simultaneously allows for efficient power transmission, reduced shock hazard, and simplified electronics for a bidirectional utility grid converter such as the X3001. The variable voltage communicates energy availability to the attached REbus™ devices, which allows for prioritized energy storage and load shedding. The microgrid is designed to support many different types of renewable energy sources and power converters, as well as accommodating future DC loads that are presently in development.

4.2 Integrated Power Line Carrier (PLC) Communications

The REbus™ microgrid standard also specifies an optional power line carrier communication technology that enables devices on the same microgrid to communicate with one another. The X3001 uses this capability to gather information about your system such as the status and energy production of your Pika T701 Wind Turbine or your solar array, which connects to the REbus™ microgrid through the Pika S2001 PV Link.

4.3 REbus™ Control Protocol (RCP)

REbus™ Control Protocol is a communications protocol developed specifically for the transfer of data between REbus-compatible power converters and data management products. RCP is an open-standard protocol which enables independent developers to interface with REbus™ products and create software and applications to enhance user experience. Please visit the Pika Energy website to learn more about RCP and the software applications that are currently available.

5 Designing a REbus™ System

Your trained and qualified installer will work with the Pika Energy technical support team to design the right system for your site. Please consult with Pika Energy sales department at (207) 887-9105 or on the web at <http://www.pika-energy.com> to find an installer near you.

The Pika Energy product system is designed from the ground up for unmatched flexibility. First and foremost, the X3001 Inverter accepts input from any combination of REbus™ compatible sources. In fact, the X3001 Inverter supports up to 32 devices on the REbus™ microgrid network, and the automatic power management capability of REbus™ allows the total power rating of sources on the network to exceed the inverter power rating by up to 2X. As of publication, Pika Energy offers the following REbus™ products in addition to the X3001 Inverter:

- T701 Wind Turbine
- S2001 PV Link
- B4001 Battery Charge Controller
- REport Data Monitor

Check the Pika Energy website at <http://www.pika-energy.com> for the latest selection of REbus-compatible product offerings.

6 Operation

6.1 Installation

Please consult the Pika X3001 Inverter Installation Manual for instruction and important safety precautions related to the installation of your new inverter. Inverter installation should only be performed by trained personnel.

6.2 Power Switch

The power switch located on the bottom side of the inverter can be used to turn your X3001 on and off. **High voltage may still be present inside the inverter and at the DC and AC terminals even when this switch is off.** Note that disconnecting the AC grid (e.g. via a service disconnect or circuit breaker) may not turn the inverter off if sources (e.g. wind or solar) are providing power to the microgrid.

6.3 Enable/Disable

The X3001 Inverter will automatically detect the presence of the grid on power-up. If the inverter was enabled prior to power down, the inverter will automatically enable and begin functioning. If it was previously disabled, it will remain disabled after powerup. If you want to disable the inverter to conserve power you can use the power switch or choose disable from the menu (see Section 7 for instructions on using the user interface menus). When disabled but powered up, the X3001 will still operate as a communications gateway for the REbus™ microgrid. Once the inverter is disabled, it will not automatically restart and energy import/export to/from the utility grid will not occur. The inverter can be enabled through the same menu.

Important! During a power failure on the public utility grid, the X3001 will automatically go to a Waiting state in which it will not attempt to import or export power. When the utility grid's power comes back and stabilizes, the X3001 will automatically restart. No user involvement is required during power outage events.

6.4 Power Outage

In the event of a power outage, the X3001 Inverter will disconnect from the utility grid automatically. When the utility grid returns and stabilizes, the inverter will automatically reconnect.

6.5 High Temperature Operation

The X3001 is designed and tested to operate continuously at full power in ambient air temperature up to 50°C. However, installation in tight spaces (e.g. closets), direct exposure to full sun, or installations that hamper the effectiveness of the passive cooling system may result in higher inverter temperatures and reduced power operation. If the maximum power has been reduced because of temperature, the **Inverter** LED on the inverter will illuminate yellow and LCD display on the inverter will display a message indicating this. While the inverter has been designed to operate in these conditions without damage, the lifetime of the inverter will be longer when operated in a lower temperature environment. It is highly recommended that the inverter be installed in well-ventilated areas, and out of direct sunlight if possible. See the Installation Manual for further information.

7. User Interface

7.1 Overview of User Interface

The X3001 user interface, available on the front cover of the inverter, is designed to provide basic information and control of the inverter and attached devices on the REbus™ Microgrid (“REbus™ devices”).

7.2 LED Displays

The X3001 user interface is equipped with three LEDs to quickly offer information about the status of the inverter and other REbus™ devices.

7.2.1 Multicolor “REbus” LED

This green/yellow/red LED indicates the status of the REbus™ microgrid and attached devices. When green, all devices are functioning normally and are either generating power or ready to generate power. When red, one or more of the REbus™ devices have a fault that requires attention before operation will continue. A red light could also indicate a fault with the REbus™ Microgrid itself (e.g. a ground fault). See the LCD Display for more information about the specific fault that has been detected.

7.2.2 Multicolor “Grid” LED

This green/yellow/red LED indicates the status of the utility grid and/or inverter itself. When green, the utility is connected and within normal operational voltage and frequency. When yellow, the utility grid is not within normal conditions, but no user intervention is typically required. The inverter will restart as soon as the utility grid returns to normal conditions. When red, a serious fault with the utility grid or inverter has been detected and user attention is required before the unit will resume operation. See the LCD Display for more information about the specific fault that has been detected.

7.2.3 Blue “Wi-Fi” LED

This blue LED is illuminated when a connection to a Wi-Fi router has been established and is operating normally.

7.3 LCD Display

The LCD Display provides access to a wealth of information about the X3001 Inverter and the other REbus™ devices. The display is organized into pages with three default pages and one additional page for each attached REbus™ device with communications capability.

7.3.1 REbus™ System Page

The REbus™ System Page gives an overview of the entire REbus™ Microgrid and attached REbus™ devices. This is the default page of the display and appears automatically on power up.

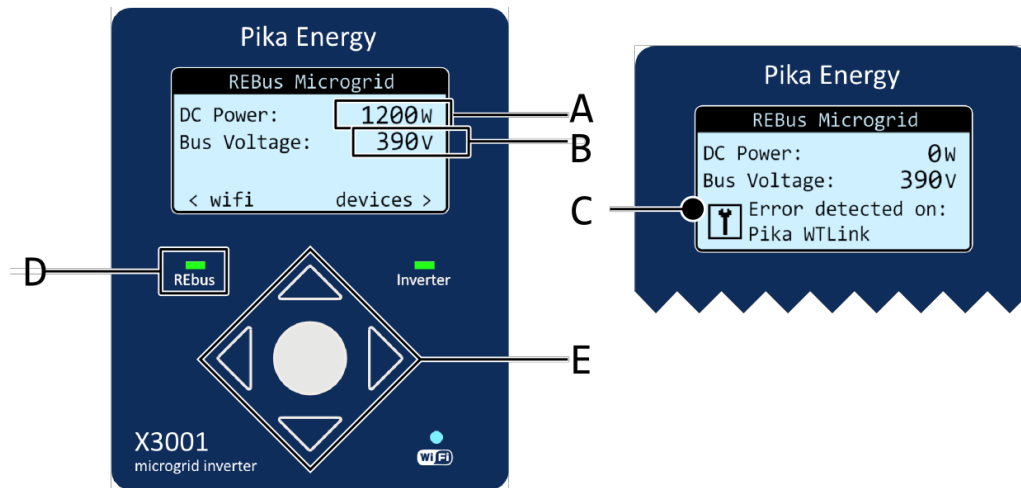

Position	Description	Explanation								
A	REBus™ DC Power	The instantaneous power being generated by REBus™ sources. This is the amount of DC power being input into the DC side of the inverter.								
B	Bus Voltage	The voltage of the electric bus that connects all of the REBus™ devices to the inverter. The normal range is 310 to 410 Volts.								
C	REBus™ Device Error Notification	This message is displayed when a REBus™ device reports an error. The message indicates which REBus™ device requires your attention.								
D	REBus™ Status Indicator LED	This LED describes the state of all of the REBus™ devices connected to the REBus™. The LED will be RED if one or more REBus™ devices are reporting an error, YELLOW if no REBus™ devices are detected, and GREEN if all REBus™ devices are reporting nominal statuses. The color of the LED does not depend on the page that you are looking at.								
E	User Input buttons	These five buttons allow the user to command the X3001. <table border="1" style="margin-left: 20px;"> <thead> <tr> <th colspan="2">Button functionality when in a menu:</th> </tr> </thead> <tbody> <tr> <td>Left</td> <td>Exit menu or cancel menu selection before confirmation.</td> </tr> <tr> <td>Up/Down</td> <td>Change menu selection. Selected item will be highlighted.</td> </tr> <tr> <td>Center</td> <td>Select current highlighted menu item</td> </tr> </tbody> </table>	Button functionality when in a menu:		Left	Exit menu or cancel menu selection before confirmation.	Up/Down	Change menu selection. Selected item will be highlighted.	Center	Select current highlighted menu item
Button functionality when in a menu:										
Left	Exit menu or cancel menu selection before confirmation.									
Up/Down	Change menu selection. Selected item will be highlighted.									
Center	Select current highlighted menu item									

Button functionality for REBus™ Information Page	
Left/Down	Scroll to the Wi-Fi information page.
Right/Up	Scroll to the Inverter information page.
Center	No functionality on the REBus™ information page.

7.3.2 X3001 Inverter Page

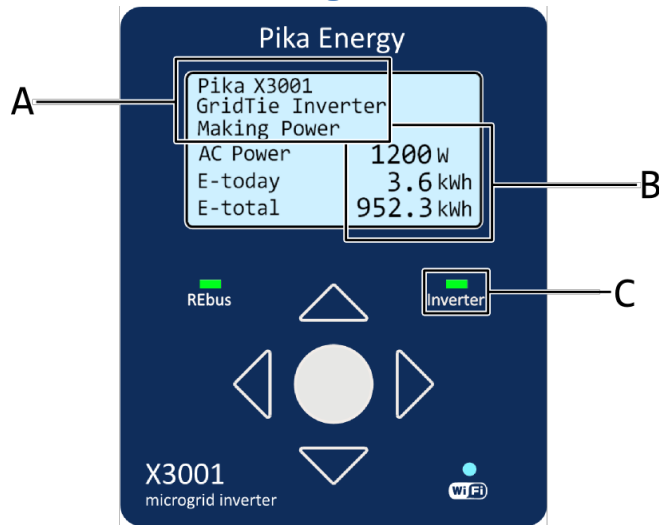

Position	Description	Explanation	
A	X3001 Status	The X3001 displays its name and status at this location. Possible status messages:	
		Powering up	The X3001 is powering up.
		Disabled	The X3001 has been disabled by the user.
		Waiting	The X3001 is waiting for a short period of time before it connects to your electric utility.
		Connecting to bus	The X3001 is connecting to your REbus™ Microgrid.
		Testing bus	The X3001 is testing the energy availability status of your REbus™ Microgrid to determine if energy export to the grid is appropriate.
		Connecting to grid	The X3001 is synchronizing to your electric utility.
		Standby	The X3001 will display this message when it is waiting for power to be produced by your REbus™ devices.
		Making power	The X3001 is ready and exporting power to your electric utility
		ERR: Ground Fault	The X3001 has detected a serious hardware failure that could result in an electric shock. DO NOT ATTEMPT to enable your X3001. Please contact Pika Energy for assistance.
	ERR: General	An unspecified error has occurred. Please contact Pika Energy for assistance.	
B	AC Power and Energy Status	The X3001 displays the instantaneous AC power being exported to your electric utility. It also tracks the amount of energy that has been exported overall and for the day.	
C	Inverter	This LED provides an indication for the status of the inverter that is	

Status LED	independent of the page you are looking at.
Inverter Status LED Color	
Yellow	The inverter is preparing to connect to your electric utility.
Blinking Green	The inverter is testing the state of the REbus™
Green	The inverter has connected to your electric utility and the REbus™
Red	The inverter has reported an error and requires your attention
Off	The user has disabled the inverter

Button functionality for inverter information page		Menu Options:	
Left/Down	Scroll to the REbus™ information page.	Enable/Disable	Instruct the inverter to enable or disable itself.
Right/Up	Scroll to the device information pages.		
Center	Open the inverter menu.		

7.3.3 Wi-Fi Status Page

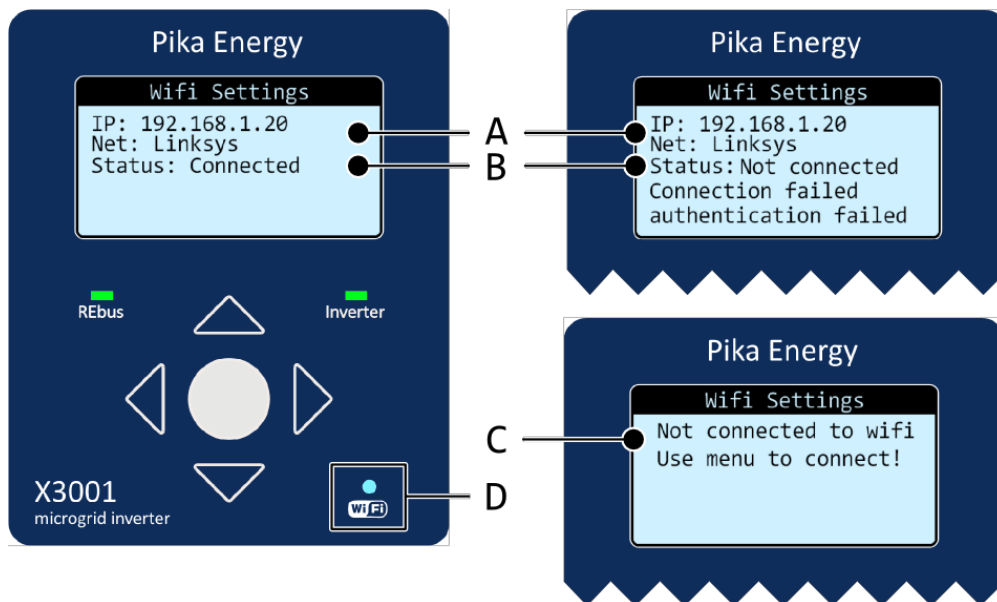

Position	Description	Explanation
A	Wi-Fi network and IP address	The X3001 displays the Wi-Fi network and IP address that it has been assigned when configured to connect to a Wi-Fi network.
B	Wi-Fi Status	The X3001 also displays the Wi-Fi connection status when configured to connect to a Wi-Fi network. The X3001 will also print the reason for a failed connection. See section 8.3 Wi-Fi Status Messages and Troubleshooting for descriptions of the connection status messages and troubleshooting information.
C	Wi-Fi activity LED	This blue LED will flash when the X3001 is communicating on a Wi-Fi network.
D	Wi-Fi settings not configured	This message is displayed when the X3001 has not been configured to connect to a Wi-Fi network, or after the Wi-Fi settings have been reset from the Wi-Fi menu.

Button functionality for Wi-Fi Information Page	
Left/Down	Scroll to the device information pages.
Right/Up	Scroll to the REbus™ information page.
Center	Open the device menu.

Menu Options:	
Setup	Set the Wi-Fi configuration settings.
Reset	Reset the Wi-Fi configuration settings and connection.

7.3.4 Other REbus Device Pages

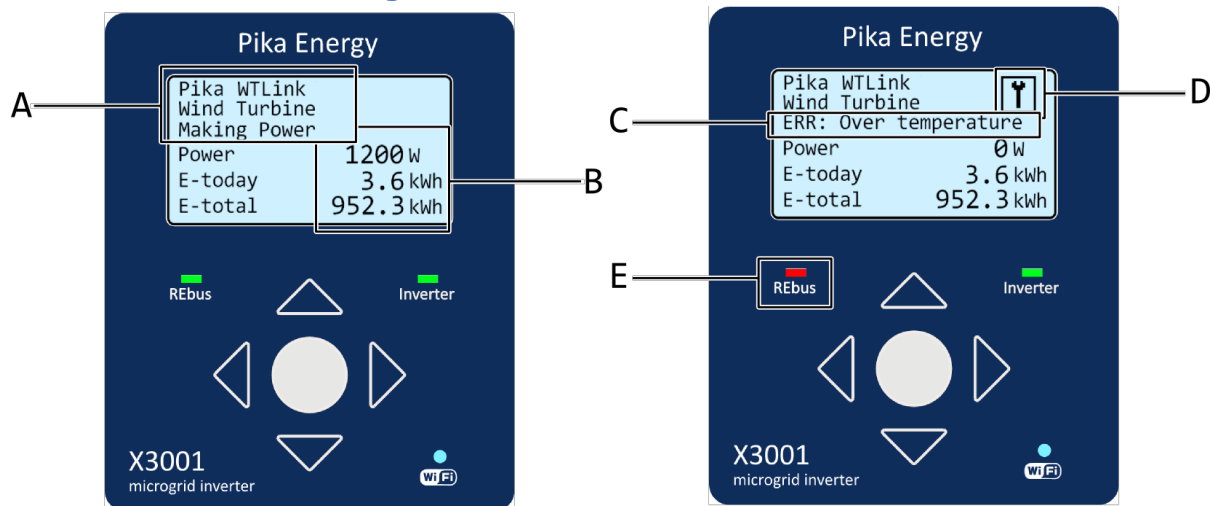

Position	Description	Explanation
A	REbus™ Device Name, Type, Status	The X3001 will display the name, device type, and status of each of the REbus™ devices.
B	REbus™ Device DC Power and Energy	The X3001 also displays the instantaneous DC power being generated (or used) by this device. The total and daily amount of energy generated is also displayed.
C	Error State Message	When the device is in an error state, the X3001 will display the error status here. Statuses are device-specific so please refer to the manual for your REbus™ device for descriptions of the status messages and troubleshooting information.
D	Error Indication Icon	This icon provides an indication that this device needs attention.
E	REbus™ Status Indicator LED	This LED describes the state of all of the REbus™ devices connected to the REbus™. The LED will be RED if one or more REbus™ devices are reporting an error, YELLOW if no REbus™ devices are detected, and GREEN if all REbus™ devices are reporting nominal statuses. The color of the LED does not depend on the page that you are looking at.

Button functionality for Device Information Page	
Left/Down	Scroll to either the next REbus™ device if there more to view, or the Wi-Fi settings page.
Right/Up	Scroll to either the previous REbus™ device if there are more to view, or the inverter information page.
Center	Open the device menu.

Menu Options:	
Enable/Disable	Instruct the inverter to enable or disable itself.
Remove	Remove this device from the display. Only useful for clearing devices that you no longer have attached to the REbus™.

7.3.5 Background Illumination

The background light is typically turned off to conserve power, however, any time a button is pressed the background light will turn on to help illuminate the display. The background light will automatically turn off after 30 seconds of inactivity.

7.4 Navigating the Menus

Five buttons allow for easy navigation of the display pages and menus. Generally the left/right buttons change pages, the center button opens a menu and the up/down buttons change between options in a list. Pika engineers have worked tirelessly to make navigation of the menus as intuitive as possible!

8 Internet Compatibility

Note! The Wi-Fi features of the X3001 are entirely optional and can be enabled/disabled in the settings menu, accessible from the user interface.

At Pika Energy, we believe that people make better energy decisions when their energy information is depicted in an easy to understand and intuitive format. For this reason, the X3001 is designed to display its vast amount of energy information on a Pika-supported website for visualization and analysis. The website offers the user several graphical options for viewing his or her energy production. These include energy (kWh) plotted monthly and daily for 30 years, hourly for the previous year and by minute for the past 24 hours.

The website also provides status reports, the daily log/error descriptions and graphics of the energy production for each component of the system.

8.1 Wi-Fi Antenna

The Pika X3001 is shipped standard with a Wi-Fi antenna that should offer good performance for most installations. For installations where the inverter is located at some distance from the Wi-Fi router, the signal strength may not be adequate. Signal strength can be monitored on the Wi-Fi Page of the LCD Display (see Section 7.3.3). In this case, a higher-gain antenna can be purchased to improve the connection to the Wi-Fi router. Most electronic component suppliers offer compatible antennas with SMA connectors. Most 802.11 antennas with SMA connectors (available from electronic component distributors) will be compatible. Alternate antennas can be purchased from Pika Energy as well.

8.2 Configuring your Wi-Fi Connection

This section will describe how to connect the X3001 to your Wi-Fi network.

The X3001 Wi-Fi connection is IEEE 802.11b compliant and connects to 802.11b/g/n routers with WEP, WPA-PSK, and WPA2-PSK security protocols.

Step 1: Navigate to the Wi-Fi information page and press the center button to open the menu:

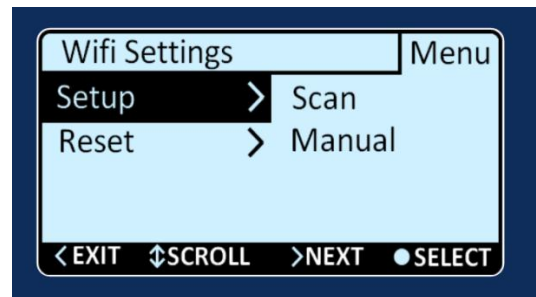

Step 2: Choose whether you want the X3001 to scan for the Wi-Fi networks or enter your Wi-Fi network parameters manually.

8.2.1 Scan-based network setup

(Scan) Step 3: If you choose “Scan”, the X3001 will scan for networks and display the results with indicators for signal strength and network security. Use the **UP** and **DOWN** arrows to select your network. Press **LEFT** to cancel the Wi-Fi configuration process. Press **CENTER** to select the highlighted network. The X3001 will then ask you for your Wi-Fi network password if your network is secured.

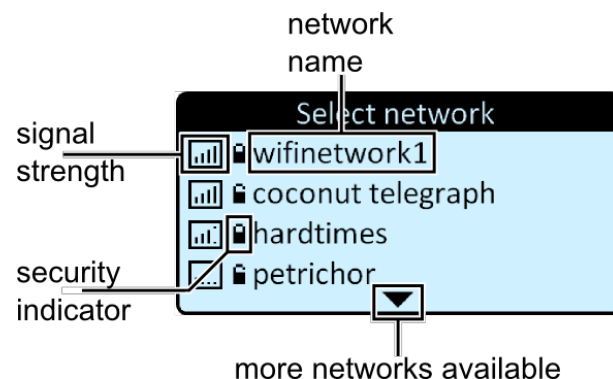

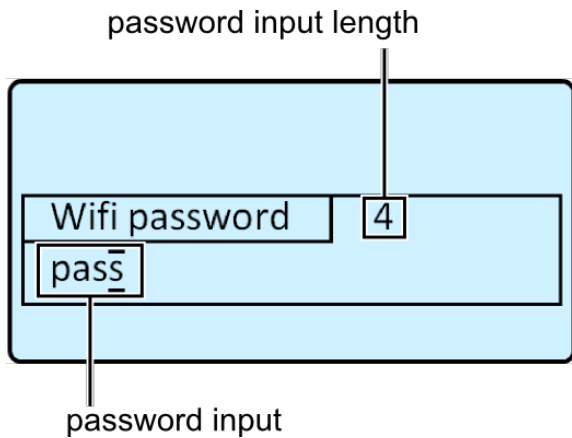

(Scan) Step 4: Enter your password by using the **UP/DOWN/LEFT/RIGHT** buttons. **RIGHT** and **LEFT** will change the cursor position. **UP** and **DOWN** will change the character at the cursor position. Press **CENTER** when you have finished entering your password. The X3001 will immediately try to connect to your network with the provided password.

8.2.2 Manual configuration network setup

(Manual) Step 3: If you choose “manual”, you will be shown the manual network setup screen shown below. Press **UP** and **DOWN** to select and **CENTER** to perform the highlighted item.

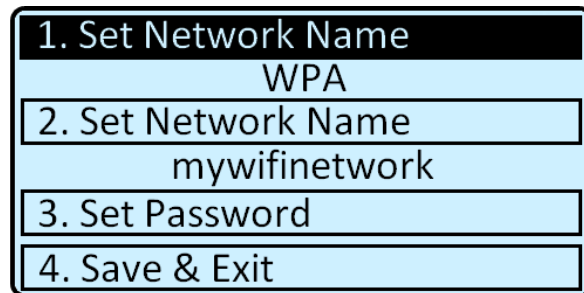

(Manual) Step 4: Enter your network type. If your network is secured with a password, consult your wireless network router to determine whether your network is WEP or WPA security. If your network is WPA or WPA2, choose the WPA option. Choose OPEN if your network does not use a password.

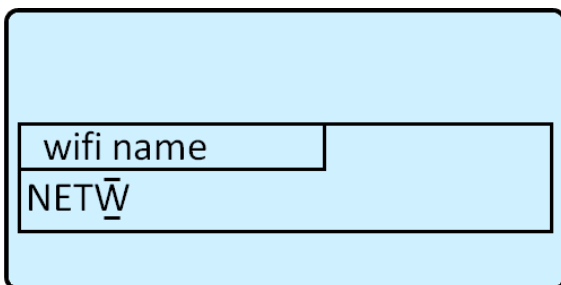

(Manual) Step 5: Enter your network name by using the **UP/DOWN/LEFT/RIGHT** buttons. **RIGHT** and **LEFT** will change the cursor position. **UP** and **DOWN** will change the character at the cursor position. Press **CENTER** when you have finished entering your network name. You will be brought back to the Manual network setup screen.

(Manual) Step 6: Enter your password by using the **UP/DOWN/LEFT/RIGHT** buttons. **RIGHT** and **LEFT** will change the cursor position. **UP** and **DOWN** will change the character at the cursor position. Press **CENTER** when you have finished entering your password. You will be brought back to the Manual network setup screen.

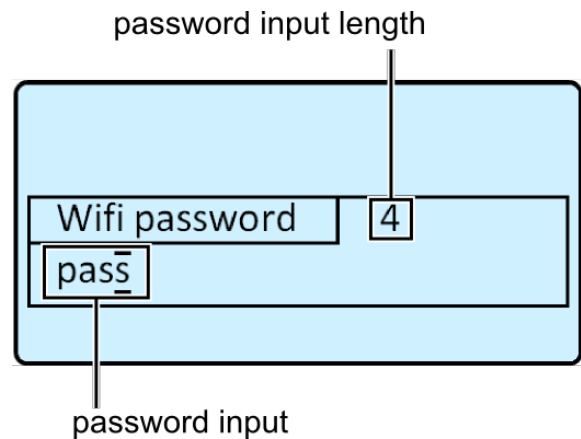

(Manual) Step 7: Select “Save & Exit” to apply your Wi-Fi network settings. The X3001 will then attempt to connect to your network with the provided configuration.

8.3 Wi-Fi Status Messages and Troubleshooting

8.3.1 Connection states:

“Status: Connected”	The X3001 has successfully connected to your Wi-Fi network.
“Status: Not connected”	The X3001 was unable to connect to your network. The additional information displayed will describe why it was unable to connect
“Status: Connecting”	The X3001 is in the processing of negotiating with your Wi-Fi network.
“Status: Reconnecting”	The X3001 was temporarily disconnected and is attempting to renegotiate with the Wi-Fi network. No user input is required.

8.3.2 Connection state messages:

“Connection failed network join failed”	This message is displayed when the X3001 has failed to connect to your Wi-Fi network but not enough information is available to determine a specific reason. In many cases this is due to poor receiver reception on the X3001. Try moving your Wi-Fi router closer to the X3001.
“Connection failed authentication failed”	This message will be displayed when the X3001 is refused by your Wi-Fi router because of an incorrect password. Re-enter your credentials to try again.
“Connection failed association failed”	This message will be displayed when the X3001 was able to authenticate itself with your network, but your router refused to let the X3001 connect. This usually means your router has been specifically configured to block the X3001 from connecting. Check your router configuration and remove it from any device block lists.
“Connection failed handshake failed”	This message will be displayed when your router and X3001 have failed to exchange encryption information. This can be caused by data corruption due to noise. Sources of this noise are microwave ovens, wireless phones, and other sources of 2.4 GHz radio. If this happens repeatedly try moving your Wi-Fi router closer to the X3001.
“Connection failed Security mismatch”	This message will be displayed if the X3001 has been configured to use the wrong type of Wi-Fi security. If you manually selected “WPA” as your network type, try using “WEP” instead. If you manually selected “WEP,” try “WPA.”
“Connection failed no suitable AP found”	This message will be displayed if the X3001 was unable to find your network after scanning. Double check that your network name is correct. If the network name is correct, the X3001 might be out of range of your Wi-Fi network. Try moving the Wi-Fi router closer to the X3001.
“Connection temp lost AP beacon timeout”	This message is displayed when the X3001 has failed to receive the “heartbeat” message that all Wi-Fi routers send. This can happen if your Wi-Fi router is being reset, powered down, or is just beyond the signal range to the X3001. The X3001 is still attempting to reconnect automatically when this message is displayed.
“Connection temp lost Deauth received”	This message indicates that your Wi-Fi router has told the X3001 to disconnect and re-authenticate itself. The X3001 will attempt to reauthorize and reconnect.
“Connection temp lost Disassociate received”	This message indicates that your Wi-Fi router has told the X3001 to reconnect. The X3001 will attempt to reconnect automatically.

“Conn permanently lost AP beacon timeout”	This message is displayed when the X3001 has failed to receive the “heartbeat” message for a long period of time. This can happen if your Wi-Fi router is powered down or is just beyond the signal range to the X3001. The X3001 has given up trying to connect to your Wi-Fi network when this message is displayed.
“Conn permanently lost Deauth received”	This message indicates that your Wi-Fi router has told the X3001 to repeatedly re-authenticate itself. This indicates an unusual authorization issue between your Wi-Fi router and the X3001. Try re-entering your network configuration on the X3001.
“Conn permanently lost Disassociate received”	This message indicates that your Wi-Fi router has told the X3001 to repeatedly reconnect. This indicates an unusual authorization issue between your Wi-Fi router and the X3001. Try re-entering your network configuration on the X3001.

8.4 Pika account and the REview™ online monitoring system

Consult with your installer or navigate online to www.pika-energy.com to set up your Pika account. Once you have created an account you will be able to view information about your Pika REbus system from anywhere in the world!

9 Maintenance

In general the Pika X3001 does not require any regular maintenance.

9.1 Replaceable Capacitor Bank

It is very unlikely that the large bank of electrolytic capacitors inside of the X3001 will fail. They have been carefully modeled and chosen to last the lifetime of the inverter. However, historically these components have a poor record in inverters offered from other manufacturers. This is what led the Pika Energy engineers to build a replaceable capacitor bank in the X3001 Inverter.

The inverter is capable of detecting capacitor failure before such failure impacts the inverter's ability to operate. In this case, the inverter display will indicate that a replacement capacitor bank should be obtained. Operation will continue until the situation becomes severe which could be weeks or years after the initial warning depending on the cause of the degradation.

If you see an error message indicating the need for capacitor replacement, contact Pika Technical Support for further information. Your installer can obtain a replacement capacitor bank and install it for you.

10 Troubleshooting

In the event the inverter is not behaving as expected, please contact your installer. They may consult the Troubleshooting section in the Installation Manual

11 Frequently Asked Questions

11.1 Why is there only one question in the FAQ?

Pika engineers are waiting for more questions to come in! So navigate to www.pika-energy.com, submit your question and perhaps it will get added to the list.

12 Specifications

Electrical

UL 1741 Rating Name	Alt Rating Name	Min	Nom	Max	Units
Maximum input voltage	Maximum microgrid voltage			420	V
Range of input operating voltage	Microgrid operating voltage range	360		400	V
Maximum input current (ac or dc)	Maximum microgrid input current			10	A
Maximum input short circuit current	Maximum microgrid short circuit current			15	A
Maximum input source backfeed current to input source	Maximum microgrid output current			10	A
Output power factor rating	AC power factor rating	.99		1.00	-
Operating voltage range (ac)		108		130	V,rms
Operating frequency range or single frequency		59.6		60.4	Hz
Nominal output voltage (ac)	Nominal AC voltage		120		V,rms
Normal output frequency	Nominal AC frequency		60		Hz
Maximum continuous output current (ac)	Maximum continuous AC current			13	A,rms
Maximum continuous output power (ac)	Maximum continuous AC power at 50C			3000	W
	Maximum continuous AC power at 60C			2700	W
Maximum output fault current	Maximum AC fault current			1	A
Maximum output overcurrent protection	Maximum AC overcurrent protection			15	A,rms
Synchronization in-rush current				1	A,rms
Trip limit and trip time accuracy			2%		
Ambient temperature		-20		60	C
Full-power operation temperature range		-20		50	C
Peak Efficiency				96.3	%
CEC Weighted Efficiency				96.0	%

General

Enclosure Type	NEMA 3R	
Enclosure Material	Powder-Coated Steel	-
Thermal Management	Passive convection cooling	-
Weight	11 (25)	kg (lb)
Size (excluding antenna)	370 wide x 357 high x 148 deep (14.6 x 14.0 x 5.8)	mm (in.)
Wire Size	8-14	AWG
Warranty	5 years standard	



Pika Energy
35 Bradley Drive Stop #1
Westbrook ME, 04092

www.pika-energy.com





Pika X3001 Inverter Installation & Service Manual

pika-energy.com



Installation & Service Manual for the X3001 REbus™ Inverter

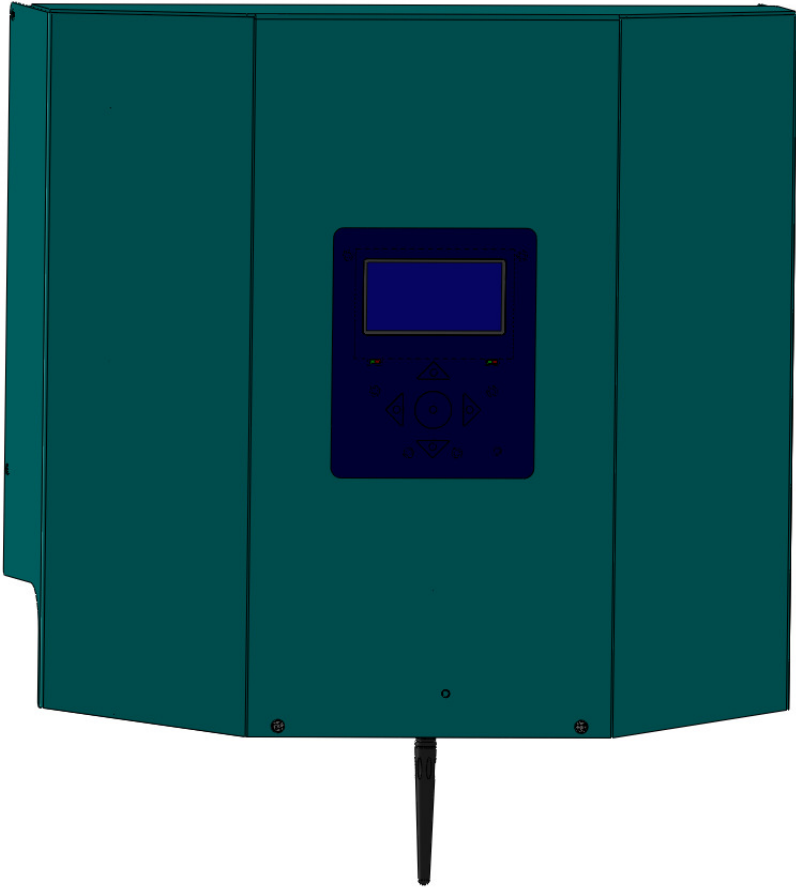

Revision Table

Revision	Date	Changes
1.0	2012-06-27	Initial Release
1.1	2012-09-17	Changes from UL1741 and CSA review
1.2	2012-11-10	Changes for Intertek listing report
1.3	2014-01-01	Updates for Gamma build
1.4	2014-10-24	REbus wiring conventions & additional troubleshooting steps

General Remarks

Congratulations! You have purchased the Pika Energy X3001 REbus™ bidirectional DC/AC inverter, a dependable, efficient component of your clean energy system. The X3001 is the result of the Pika team's careful development and testing, building on decades of experience in the fields of power electronics and renewable energy systems.

The X3001 is an electrically non-isolated single-stage inverter designed for high-efficiency bidirectional conversion between a REbus™ Microgrid and 220-240 VAC 60 Hz split-phase utility service. This inverter is passively cooled for high reliability and low noise. A replaceable capacitor bank ensures that even in the unusual event of capacitor failure, an easy remedy is available. An illuminated display and intuitive system of menus enable you to display the energy output of every component of your renewable energy system, including the energy exported by the inverter to the grid. The inverter also serves as an information gateway, enabling monitoring and control of your entire renewable energy system.

Unlike conventional inverters, which only connect to one type of energy source, Pika's X3001 is designed to operate as the hub for an expandable network of renewable energy devices, based on the REbus™ renewable energy standard.

What is REbus™?

The underlying technology behind Pika Energy's X3001 Inverter is an innovative energy management technology or 'smart microgrid' called REbus™. REbus™ is a DC energy network that operates alongside the existing AC infrastructure, enabling customers to build cost-effective, scalable renewable energy systems. The REbus™ network is designed to serve as an open interconnection standard for networking next-generation energy technology – like Wi-Fi or USB for green energy!

IMPORTANT! Only REbus™ compatible components may be used in connection with this inverter. Do not connect the output of a PV array or any other non-REbus™ electrical source to the inverter terminals. Serious property damage and/or personal injury may result.

Contents

1	Regarding this Document.....	4
1.1	Symbols used in this document	4
1.2	Standards	4
1.3	Data Label	4
2	Important safety information and instructions	5
2.1	Appropriate Usage	5
2.2	AC Output Details.....	5
3	Notes concerning installation and operation	6
3.1	Intended (normal) use	6
3.2	Pika Energy Factory Limited Warranty.....	6
3.3	Service.....	8
4	The REbus™ Microgrid.....	9
4.1	Simple and efficient power distribution	9
4.2	Integrated Power Line Carrier (PLC) communications.....	9
4.3	REbus™ Control Protocol (RCP).....	9
5	Designing a REbus™ system	10
6	Installation	11
6.1	Checking for shipping damage.....	11
6.2	Inverter mounting.....	11
6.3	Electrical connection notes.....	15
6.4	AC utility connection.....	16
6.5	REbus™ DC connection	16
6.6	Wiring the inverter.....	17
6.7	Commissioning the inverter.....	19
6.8	Operation	19
7	Troubleshooting.....	20

1 Regarding this Document

This manual contains important instructions for the X3001 Inverter that must be followed during installation and maintenance of the inverter. The X3001 is designed and tested according to international safety requirements, but as with all electrical and electronic equipment, certain precautions must be observed when installing and/or operating the X3001. To reduce the risk of personal injury and to ensure the safe installation and operation of the X3001, you must carefully read and follow all instructions, cautions and warnings in this user manual.

Store this manual so that it is always easily accessible.

1.1 Symbols used in this document



WARNING: This indicates a fact or feature very important for the safety of the user to prevent injury or death and/or which can cause serious hardware damage if not applied appropriately.



CAUTION: Presents information to prevent damage to this product



EARTH GROUND SYMBOL

1.2 Standards

The Pika X3001 Bidirectional REbus™ Inverter is certified by Intertek to be compliant with the UL 1741/IEEE 1547 standards as they apply to utility-interactive inverters.

1.3 Data Label

A permanently affixed label indicating the device specifications, serial number, and manufacturing date is located on the bottom surface of the inverter enclosure. Tampering with label can void warranty.

2 Important safety information and instructions

IMPORTANT SAFETY INSTRUCTIONS

SAVE THESE INSTRUCTIONS

This manual contains important instructions for model X3001 that shall be followed during installation and maintenance of the Pika X3001 Inverter.



WARNING: Before installing the Pika Energy X3001 Inverter, read all instructions and caution markings in this manual and on the X3001 as well as on other REbus™ devices.



WARNING: Electrical installation in the United States shall be done in accordance with all local electrical codes and/or the National Electrical Code (NEC), ANSI/NFPA 70.



WARNING: Electrical installation in Canada shall be done in accordance with all local electrical codes and/or the Canadian Electrical Code.



WARNING: Connecting the X3001 to the electric utility grid must only be done after receiving prior approval from the utility company and installation completed only by qualified personnel/licensed electrician(s).

2.1 Appropriate Usage

The X3001 is an electrically non-isolated single-stage inverter designed for high-efficiency bidirectional conversion between a REbus™ microgrid and a 220-240 VAC split-phase utility. Refer to this inverter installation manual for detailed information about the product and its intended use. The inverter may only be operated with REbus™ devices. Do not use the inverter for purposes other than those described here. Alternative uses, modifications to the inverter or the installation of components not expressly recommended or sold by the manufacturer void the warranty claims and operating permission. Contact the Pika Energy technical support if you need clarification regarding proper use of the inverter.

2.2 AC Output Details

The X3001 is to be connected to a split-phase 220-240VAC utility only. This means 120VAC from line to neutral and 240VAC from line to line. The AC neutral is not bonded to ground in the inverter. It is the responsibility of the installer to bond neutral to ground externally. The input and output circuits are isolated from the enclosure. System grounding to the ground lugs provided in the wiring box is the responsibility of the installer.

3 Notes concerning installation and operation

3.1 Intended (normal) use

Your inverter is strictly constructed according to approved safety requirements. Improper use may lead to lethal hazards for operators and/or damage to devices and property. The X3001 is certified to comply with the UL 1741 standard for utility-interactive devices, and includes important safety features including ‘anti-islanding’, which shuts down the inverter in the event of a grid power failure to avoid back-feeding power during a grid outage, which could result in injury to utility repair personnel. Improper use or modification of the X3001 may result in serious property damage, personal injury or death.

REBUS™ INPUT ONLY! The X3001 is designed to accept regulated direct current (DC) from REbus™-compatible devices (e.g. REbus™-compatible wind turbine, REbus™-compatible PV Link unit) into grid-compatible alternating current (AC). DO NOT CONNECT PHOTOVOLTAIC MODULES DIRECTLY TO THE REBUS™ INPUTS OF THE X3001 INVERTER. DOING SO WILL VOID THE WARRANTY AND MAY DAMAGE THE INVERTER.

The X3001 is typically operated in conjunction with a fixed connection to the utility grid, however it may be operated in conjunction with an approved standalone inverter as listed in the [X3001 AC Coupling Application Note](#), available by contacting Pika Technical Service. This unit is provided with fixed trip limits and shall not be aggregated above 30 kW on a single Point of Common Connection.

Any use other than the specified intended use shall not be deemed intended or normal use, and may result in property damage, personal injury or death. Pika is not liable for damage or injuries caused by unintended use.

Damage caused by unintended use is at the sole risk of the operator.

“Intended use” shall also include adherence to the operating and installation instructions.

Your trained and authorized installer must obtain all necessary permits and agreements from your local government and your utility company for a legal and code-compliant installation of your REbus™ Smart Microgrid system. See the User Manual for more detail.

3.2 Pika Energy Factory Limited Warranty

Pika Energy LLC (“Pika”) has developed a reliable, efficient inverter, designated X3001 (“Inverter”), that is designed to withstand normal operating conditions when used in accordance with its intended use and in compliance with instructions in the accompanying Installation Manual and User Manual shipped with the unit. The Pika limited warranty (“Limited Warranty”) covers defects in workmanship and materials of the Pika Inverter (“Defective Product”) for a period of five (5) years from the date of original purchase of such Inverter at point of sale to the originally-installed end user location (the “Warranty Period”). During the Warranty Period, the warranty is transferable to a different owner as long as the Inverter remains installed at the originally-installed end user location.

During the Warranty Period, if Pika determines through inspection the existence of a defect that is covered by the Limited Warranty, Pika will at its option, either (1) repair or replace the Defective Product free of charge, or (2) provide a credit or refund to the owner of the system at the originally installed end user location in an amount not to exceed the then-current price of (a) a “like kind” inverter that is available for purchase by the system owner at the time of the Limited Warranty claim, or (b) the original cost of the Pika Inverter that is subject to a Limited Warranty claim.

If Pika elects to repair or replace the Defective Product, Pika will, at its option, use new and/or reconditioned parts in repairing or replacing the Defective Product. Pika reserves the right to use parts or products of original or improved design in the repair or replacement of Defective Product. If Pika repairs or replaces a Defective Product, the Limited Warranty continues on the repaired or replacement product for the remainder of the original Warranty Period or ninety (90) days from the date of Pika’s return shipment of the repaired or replacement product, whichever is later. The Limited Warranty covers both parts and labor necessary to repair the Defective Product (if Pika elects to repair the Defective Product), but does not include labor costs related to (i) un-installing the Defective Product or (ii) if applicable, re-installing a repaired or replacement product. To the extent applicable, the Limited Warranty also covers the costs of shipping a repaired or replacement product from Pika, via a non-expedited freight carrier selected by Pika, to locations within the United States (including Alaska and Hawaii) and Canada, but not to other locations outside the United States or Canada. The Limited Warranty does not cover, and Pika will not be responsible for, shipping damage or damage caused by mishandling by the freight carrier and any such damage is the responsibility of the freight carrier.

To obtain repair or replacement service, credit or refund (as applicable) under this Limited Warranty, the customer must comply with the following policy and procedure:

- Many problems can be addressed in the field. Prior to returning a product, customer must contact Pika technical support to evaluate and troubleshoot the problem in the original installation setting.
- All Defective Product must be returned with a Return Merchandise Authorization Number (RMA) which customer must request from Pika.
- Requests for RMA must include the following information:
 - Proof-of-purchase of the Defective Product in the form of (1) the dated purchase receipt from the original purchase of the product at point of sale to the end user, or (2) the dated dealer invoice or purchase receipt showing original equipment manufacturer (OEM) status, or (3) the dated invoice or purchase receipt showing the product exchanged under warranty
 - Model number of the Defective Product
 - Serial number of the Defective Product
 - Detailed description of the defect.
 - Shipping address for return of the repaired or replacement product (as applicable).
- All Defective Product authorized for return must be returned in the original shipping container or other packaging that is equally protective of the product.
- The returned Defective Product must not have been disassembled or modified without the prior written authorization of Pika.

Pika Inverters are designed to withstand normal operating conditions and typical wear and tear when used for their original intent and in compliance with the installation and operating instructions supplied with the original equipment. The Limited Warranty does not apply to, and Pika will not be responsible

for, any defect in or damage to any Pika inverter: (1) that has been misused, neglected, tampered with, altered, or otherwise damaged, either internally or externally; (2) that has been improperly installed, operated, handled or used, including use under conditions for which the product was not designed, use in an unsuitable environment, or use in a manner contrary to the Pika User Manual or applicable laws or regulations; (3) that has been subjected to fire, water, generalized corrosion, biological infestations, acts of God, or input voltage that creates operating conditions beyond the maximum or minimum limits listed in the Pika Inverter specifications, including high input voltage from generators or lightning strikes; (4) that has been subjected to incidental or consequential damage caused by defects of other components of the system; or (5) if the original identification markings (including trademark or serial number) of such Inverter have been defaced, altered, or removed. The Limited Warranty does not cover costs related to the removal, installation or troubleshooting of the customer's electrical systems. The Limited Warranty does not extend beyond the original cost of the Pika Inverter.

THE LIMITED WARRANTY IS THE SOLE AND EXCLUSIVE WARRANTY GIVEN BY PIKA AND, WHERE PERMITTED BY LAW, IS MADE EXPRESSLY IN LIEU OF ALL OTHER WARRANTIES, EXPRESS OR IMPLIED, STATUTORY OR OTHERWISE, INCLUDING, WITHOUT LIMITATION, WARRANTIES OF TITLE, QUALITY, MERCHANTABILITY, FITNESS FOR A PARTICULAR PURPOSE OR NONINFRINGEMENT OR WARRANTIES AS TO THE ACCURACY, SUFFICIENCY OR SUITABILITY OF ANY TECHNICAL OR OTHER INFORMATION PROVIDED IN MANUALS OR OTHER DOCUMENTATION. IN NO EVENT WILL PIKA BE LIABLE FOR ANY SPECIAL, DIRECT, INDIRECT, INCIDENTAL OR CONSEQUENTIAL DAMAGES, LOSSES, COSTS OR EXPENSES HOWEVER ARISING, WHETHER IN CONTRACT OR TORT, INCLUDING WITHOUT LIMITATION ANY ECONOMIC LOSSES OF ANY KIND, ANY LOSS OR DAMAGE TO PROPERTY, OR ANY PERSONAL INJURY.

To the extent any implied warranties are required under applicable law to apply to the Pika Inverter, such implied warranties shall be limited in duration to the Warranty Period, to the extent permitted by applicable law. Some states and provinces do not allow limitations or exclusions on implied warranties or on the duration of an implied warranty or on the limitation or exclusion of incidental or consequential damages, so the above limitation(s) or exclusion(s) may not apply. This Limited Warranty gives the customer specific legal rights, and the customer may have other rights that may vary from state to state or province to province.

3.3 Service



WARNING: Do not attempt to repair the X3001 Inverter. The inverter contains no user-serviceable parts.

If the Pika X3001 Inverter fails, first contact Pika customer service at (207) 887-9105 for troubleshooting help. See the Warranty section for details on terms and conditions for repair or replacement under warranty. You must obtain an RMA (Returned Merchandise Authorization) number prior to returning the unit. Obtain the assistance of a skilled and qualified installer to safely disconnect the inverter for shipment.

Technical Support Information:

- Support department hours: 9AM to 5PM, Monday – Friday (excluding holidays)
- Phone: (207) 887-9105
- Email: support@pika-energy.com

4 The REbus™ Microgrid

The REbus™ Microgrid is the underlying technology that allows for the efficient and robust interconnection of different types of renewable energy products and loads. This section is informational only and not required knowledge for operation of your Pika X3001 Inverter.

4.1 Simple and efficient power distribution

The REbus™ Microgrid architecture was designed with renewable energy in mind. A clean-sheet approach to power distribution resulted in the most practical and efficient interconnection technology available. The microgrid operates at variable voltage in a defined band, between +/- 180-200 V relative to ground which simultaneously allows for efficient power transmission, reduced shock hazard, and simplified electronics for a bidirectional utility grid converter such as the X3001. The variable voltage communicates energy availability to the attached REbus™ devices, which allows for prioritized energy storage and load shedding. The microgrid is designed to support many different types of renewable energy sources and power converters, as well as accommodating future DC loads that are presently in development.

4.2 Integrated Power Line Carrier (PLC) communications

The REbus™ microgrid standard also specifies an optional power line carrier communication technology that enables devices on the same microgrid to communicate with one another. The X3001 uses this capability to gather information about your system such as the status and energy production of your Pika T701 Wind Turbine or your solar array, which connects to the REbus™ microgrid through the Pika S2001 PV Link.

4.3 REbus™ Control Protocol (RCP)

REbus™ Control Protocol is a communications protocol developed specifically for the transfer of data between REbus™-compatible power converters and data management products. RCP is an open-standard protocol which enables independent developers to interface with REbus™ products and create software and applications to enhance user experience. Please visit the Pika Energy website to learn more about RCP and the software applications that are currently available.

5 Designing a REbus™ system

Your trained and qualified installer will work with the Pika Energy technical support team to design the right system for your site. Please consult with Pika Energy sales department at (207) 887-9105 or on the web at <http://www.pika-energy.com> to find an installer near you.

The Pika Energy product system is designed from the ground up for unmatched flexibility. First and foremost, the X3001 Inverter accepts input from any combination of REbus™-compatible sources. In fact, the X3001 Inverter supports up to 32 devices on the REbus™ microgrid network, and the automatic power management capability of REbus™ allows the total power rating of sources on the network to exceed the inverter power rating by up to 2X. As of publication, Pika Energy offers the following REbus™ products in addition to the X3001 Inverter:

- T701 Wind Turbine
- S2001 PV Link
- B801 Battery Charge Controller
- REport Data Monitor

Check the Pika Energy website at <http://www.pika-energy.com> for the latest selection of REbus™-compatible product offerings.

6 Installation

6.1 Checking for shipping damage

The X3001 Inverter is thoroughly checked and tested before it is shipped. The inverters can be damaged in shipping, despite the carefully designed cardboard packaging.

Please inspect the inverter thoroughly after it is delivered. If any damage is seen please immediately notify the shipping company. If there is any question about potential shipping damage, contact Pika Energy. Please capture a photograph of the damage if possible.

Do not accept unit if visibly damaged or note visible damage when signing shipping company receipt. Report damage immediately to the shipping company. Do not remove the unit from its packaging. If it is determined that the unit must be returned, a RMA# must be obtained from Pika Energy.

6.2 Inverter mounting

The X3001 Inverter is a powder-coated steel enclosure (see Figure 1 for dimensions). The inverter is shipped complete and does not require a separate mounting bracket. A wall mounting bracket to permit mounting on a narrow structural member (e.g. stud) may be available, contact Pika Energy for details.

- For the longest possible life, the X3001 should be mounted out of direct rain, either under a weather proof overhang or indoors.
- The inverter should be restricted from direct sun exposure by mounting on the North side of a building or structure, indoors, or behind a sun shield. This will best prevent power derating due to inverter heatsink temperatures above 50 C. The maximum ambient temperature is 60 C. See Operations manual for additional details.
- If feasible, the inverter should be installed away from areas where animals congregate, as the high frequency (33 kHz) switching of the electronics may disturb them.
- During operation, the inverter heatsink may be hot and should be situated in locations where it will not be subject to incidental contact.
- Installation in close proximity to the AC distribution panel may eliminate the need for a supplemental AC service disconnect. Consult local inspectors or the NEC for details.
- The passive cooling system in the Pika X3001 will work best when the inverter is mounted on a flat, smooth, vertical wall.
- Minimum clearances must be maintained, as shown in Figure 2 below.

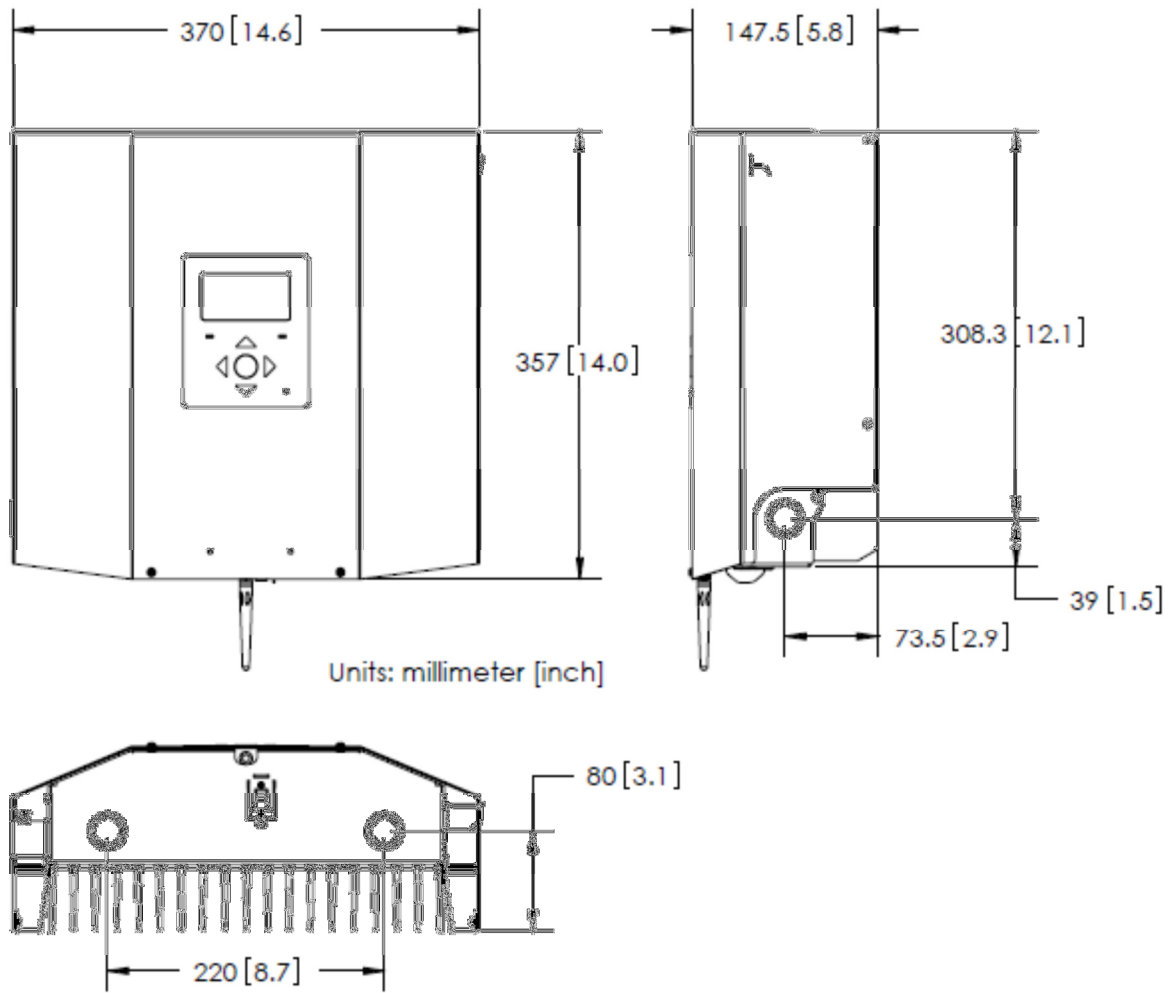

Figure 1 Pika X3001 Dimensions

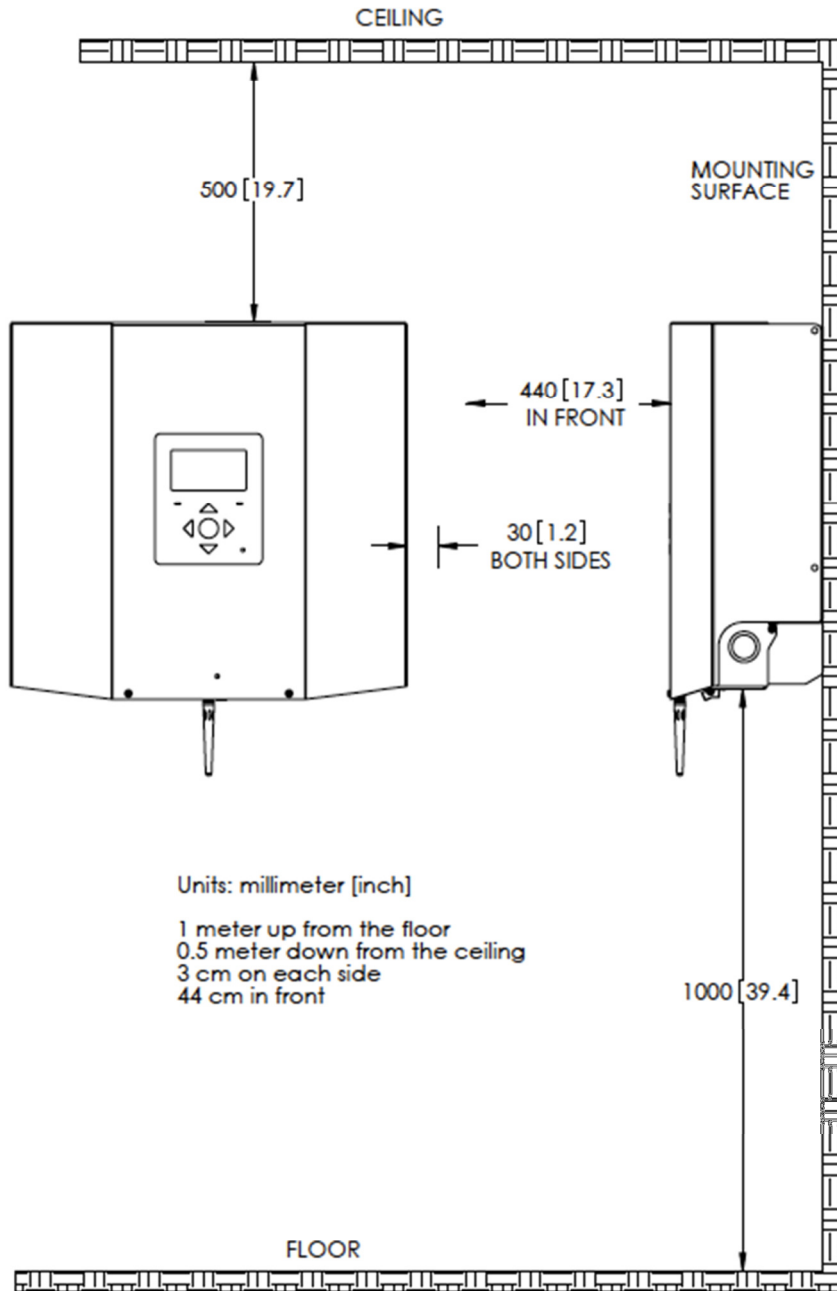

Figure 2 Inverter Minimum Clearance

Mounting surface must be suitable for installing #10 (~M5) pan head screws (suitable for tightening with screwdriver). These screws can be installed in wood, metal, or masonry. If screw anchors are used (e.g. concrete expansion anchor), they must be rated to hold the 11 kg (25 lb) inverter with appropriate safety factor. Drywall is not a recommended mounting surface for the inverter. Mounting surface should be vertical.

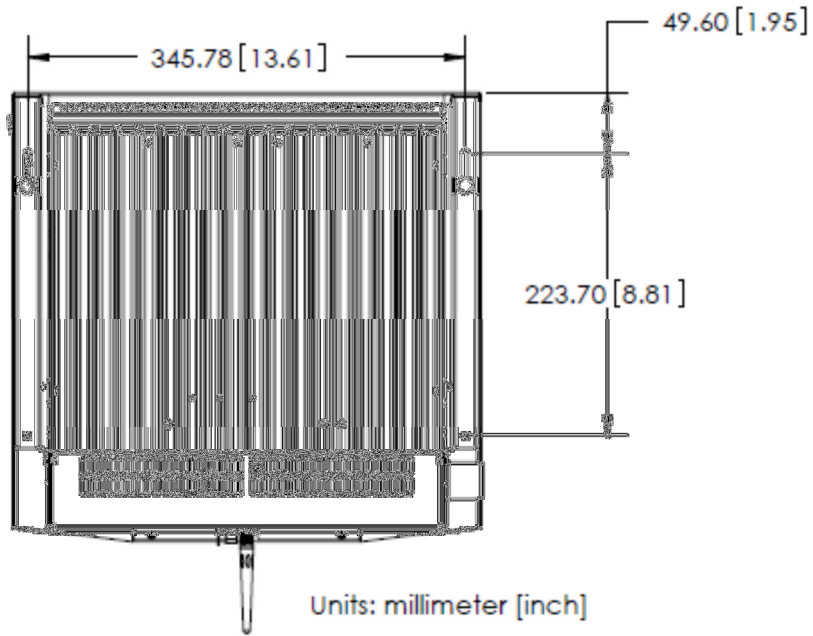

Figure 3 Mounting Hole Diagram

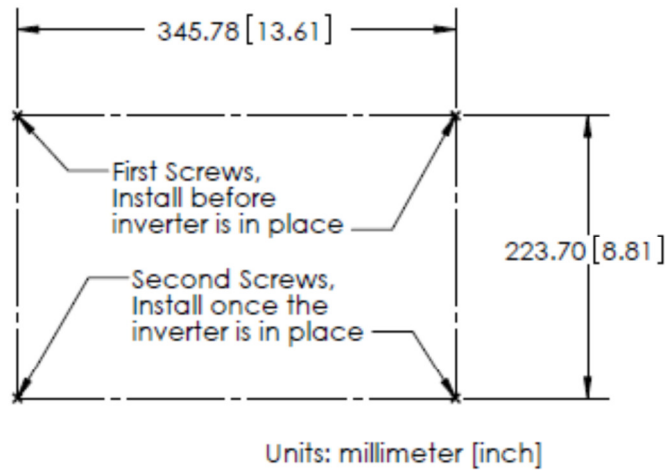

Figure 4 Mounting Screw Diagram

Use the included mounting template to accurately mark and drill holes for installing the X3001. Install two of the included screws into mounting surface 345.8 mm (13.6 in.) apart as shown in Figure 4. Leave a minimum of a 3 mm gap between the head of the screw and the mounting surface to accept the enclosure foot. Install inverter over these two screws. Remove M3 screws securing inverter cover and open cover. Install second two #10 (or equivalent) screws in lower mounting holes. Tighten all screws.

6.3 Electrical connection notes

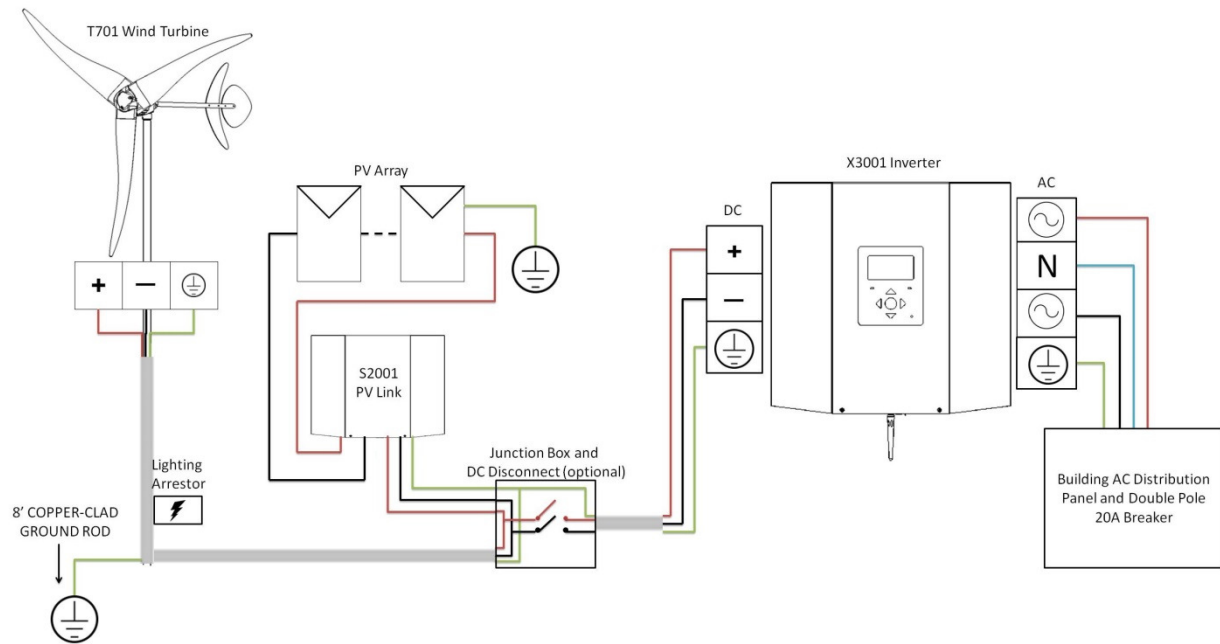

Figure 5 Example X3001 system layout with S2001 PV Link and T701 Wind Turbine



WARNING: All electrical installations in the United States shall be done in accordance with all local electrical codes and/or the National Electrical Code (NEC), ANSI/NFPA 70.



WARNING: Electrical installation in Canada shall be done in accordance with all local electrical codes and/or the Canadian Electrical Code.



WARNING: To reduce the risk of fire, always connect the inverter to a dedicated 15A (or 20A) 2-pole circuit breaker without multiwire branch circuits.

The X3001 Inverter is equipped with concentric electrical knockouts suitable for $\frac{1}{2}$ or $\frac{3}{4}$ " conduit fittings. Pika Energy recommends the use of conduit fittings (hubs) which are raintight or wet location hubs that comply with the requirements in the Standard for Fittings for Conduit and Outlet Boxes, UL 514B. AC & DC terminals allow for 14 to 8 AWG copper conductors. Earth ground terminals allow for 14 to 8 AWG copper or aluminum conductors.

6.4 AC utility connection



WARNING: The wiring of the inverter's AC connections must only be done with the AC distribution panel circuit breaker off.



WARNING: Perform a high potential test on all existing wiring before any connections are made! **Never trust existing wiring** until a high potential test has been performed. Pika recommends 1kV testing on all REbus™ wiring. Failure to high potential test existing wiring before installation will void warranty! For questions concerning high potential testing contact Pika Technical Support.

The X3001 is a 240V/60Hz AC grid-connected inverter. Specifically, a split-phase connection with a neutral is required. It cannot be used with a 120 V AC single-phase connection. A dedicated 15 (or 20) amp 2-pole circuit breaker is required for each inverter. An AC service disconnect may be required by local codes or the NEC.

Multiple X3001 units can be used at the same location/facility assuming all codes are followed including NEC, local building codes and area utility guidelines. If multiple units are used, each inverter should have its own dedicated circuit breaker. Contact Pika about configuring the power line communications in applications with adjacent inverters.

For 50Hz applications, contact Pika Energy for a X3001/50Hz product.

6.5 REbus™ DC connection



WARNING: The wiring of the inverter's REbus™ connections must only be done with the AC distribution panel circuit breaker off and REbus™ sources (e.g. S2001 PV Link, T701 Wind Turbine) either disabled or generation capability removed. Completely cover the surface of all PV arrays with opaque (dark) material, remove string fuses, or use other methods to ensure PV cannot output power to the S2001 PV Link. Lower T701 to ground and secure blades from spinning. Alternatively, disable S2001 PV Link or T701 Wind Turbine using X3001 Inverter interface. Confirm with a meter that the REbus™ Microgrid is below 50 VDC before performing any wiring operations.



WARNING: Hazardous voltage is still present on the REbus™ inverter after disconnection of all inputs (AC and DC). Allow 3 minutes for the inverter to discharge the DC voltage completely.



WARNING: Perform a high potential test on all existing wiring before any connections are made! **Never trust existing wiring** until a high potential test has been performed. Pika recommends 1kV testing on all REbus™ wiring. Failure to high potential test existing wiring before installation will void warranty! For questions concerning high potential testing contact Pika Technical Support.

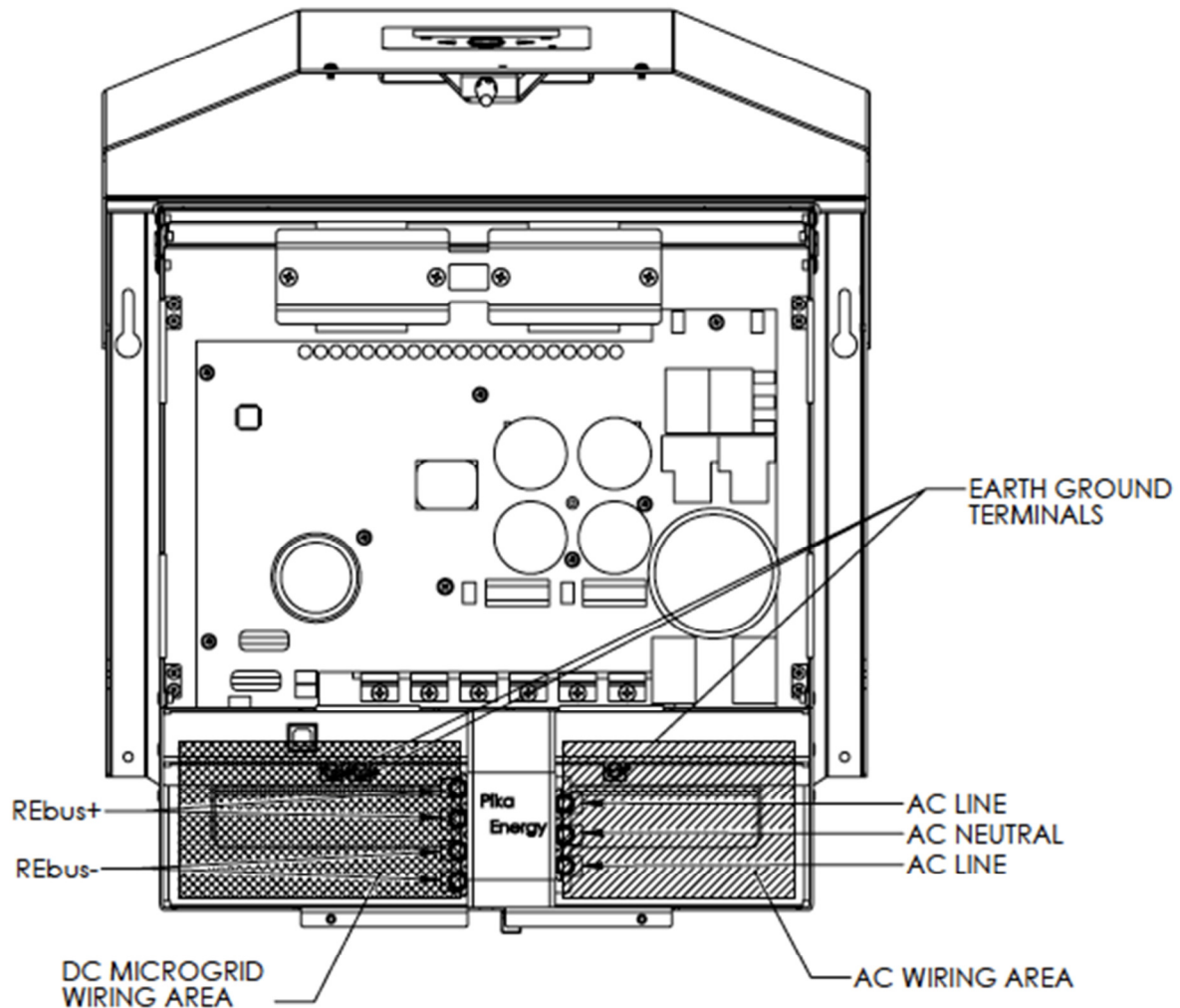



Figure 5 Wiring Diagram

6.6 Wiring the inverter

1. Open inverter cover by hinging up, position the kickstand on the right side to catch and support the lid.
2. Remove electrical conduit knockouts, either $\frac{1}{2}$ " or $\frac{3}{4}$ ", on the side or bottom surface of inverter. Install electrical conduit.
3. The AC distribution panel circuit breaker should be off and REbus™ sources (e.g. S2001 PV Link, T701 Wind Turbine) either disabled or generation capability removed before any wiring is connected. Completely cover the surface of all PV arrays with opaque (dark) material, remove string fuses, or use other methods to ensure PV cannot output power to the S2001 PV Link.

Lower the T701 to ground and secure blades from spinning. Confirm with a voltmeter that the REbus™ is below 50 VDC before performing any wiring operations.

4. Run wires from AC distribution panel to inverter, connect to terminals (reference Figure 5 for wiring locations), torque to 2.1 Nm (18.5 in-lb)

5.  **WARNING:** Before wiring the DC (REbus™) side of the inverter, ensure all REbus™ wiring in follows the wiring convention described below:

RE+ : Red wire (alternatively, white wire marked with at least three continuous wraps of red electrical tape at all terminations, as shown below)

RE- : Blue wire (alternatively, black wire marked with at least three continuous wraps of blue electrical tape at all terminations, as shown below)

Ground: Green wire (alternatively, bare wire)

6. Run wires from REbus™ DC sources to inverter, connect to terminals (reference Figure 5 for wiring locations), torque to 2.1 Nm (18.5 in-lb). See Figure 6 REbus™ Wiring Color Code for wiring reference.

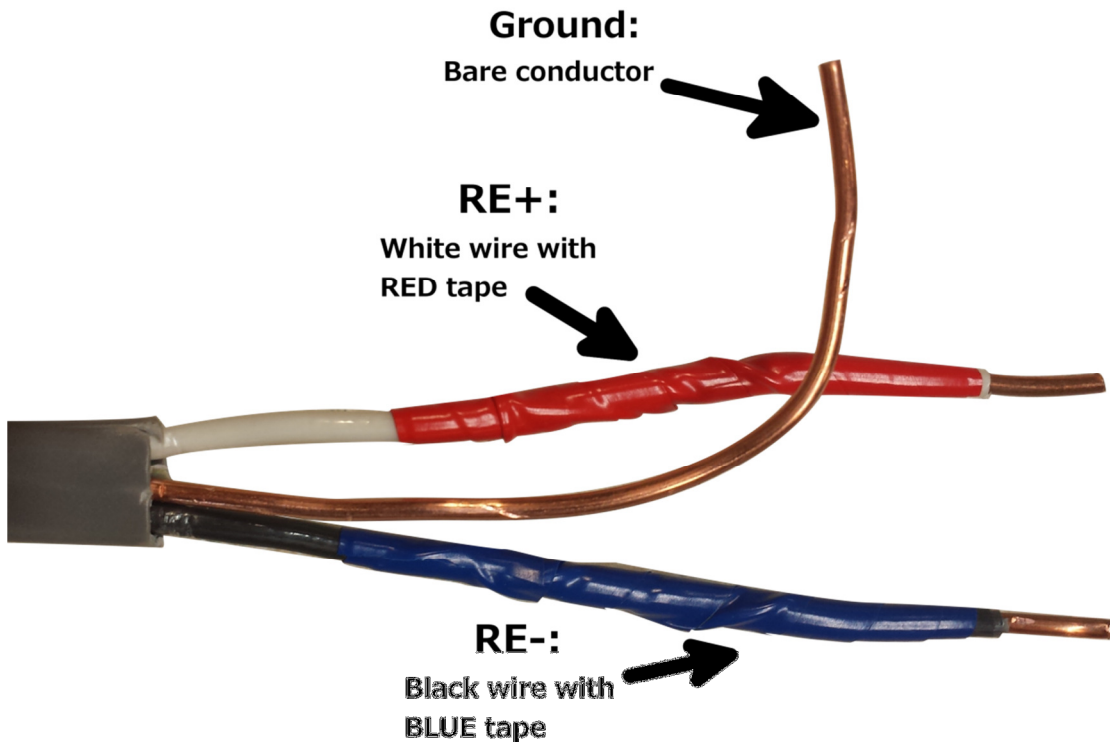

Figure 6 REbus™ Wiring Color Code

7. Connect earth ground wires, torque to as follows:

Wire Size	Screw Torque
8 AWG	4.5 Nm (40 in-lb)
10-14 AWG	4.0 Nm (35 in-lb)



WARNING: Make a final check for correctness of all AC and DC wiring to the inverter and in the system. In particular, check that the polarity of the DC wiring is correct throughout the entire system. **Reverse polarity will damage system components**, may create a fire hazard and will void inverter warranty!

8. Close inverter cover and install two cover screws.

6.7 Commissioning the inverter

Once the inverter is mounted, and both AC and REbus™ microgrid connections have been made, ensure the inverter enclosure lid is securely attached with its mounting screws. Ensure no wiring is accessible by personnel (install covers on junction boxes, attach shroud on turbine, etc). The inverter is now ready to power ON in accordance with the following steps:

1. Turn on the system DC disconnect (if the system is equipped with optional DC disconnect)
2. Turn on the dedicated 2-pole circuit 240/208VAC circuit breaker on the home/building electrical panel
3. Turn on the system AC disconnect (if the system is equipped with additional AC disconnect)
4. Turn on the power switch on the bottom surface of the inverter.
5. Watch the LCD for initialization sequence.
6. Use the arrow keys to scroll to the inverter page. Enable the inverter by pressing the center button, selecting “Enable” and press “Confirm”. If this is the first time powering up the inverter, devices connected on REbus™ will be automatically discovered.
7. See the X3001 Operation Manual for enabling REbus™ devices, connecting to Wi-Fi and other system configuration.

6.8 Operation

Please consult the Pika X3001 User Manual for instruction and important safety precautions related to the operation of your new inverter. Inverter operation is best performed by persons who have read and understand the user manual.

7 Troubleshooting

The following table offers a few initial actions to try in the event that the inverter is not functioning as expected. Contact technical service if the symptoms persist.



WARNING: Disconnect all AC power and disable sources of DC power before troubleshooting any wiring. Always check wiring with a voltmeter to ensure safe working conditions! Do not open the lid of the inverter without turning off all sources of power connected to it.

Symptom	Action
Unit does not power up	<ol style="list-style-type: none"> 1) Check that AC power in the range of 110-130 VAC is present between each of the AC line terminals and ground 2) Toggle the power switch on the bottom side of the inverter
Ground Fault	<ol style="list-style-type: none"> 1) Turn off the AC breaker that feeds the inverter. Verify no voltage is present on AC or DC wiring and disconnect the REbus™ (DC) side wiring and ensure it is not touching anything. Power ON the inverter and make sure the ground fault message is no longer displayed. 2) Check the wiring on the REbus™ (DC) side. Ensure that none of the DC wires are touching the enclosure or earth ground wires. RE+ and RE- should measure >1MΩ to ground with a multimeter. Some possible scenarios: incorrect REbus™ wiring, lightning arrestor failed, chaffed wire insulation, or broken wire.
Unit displays waiting state	<ol style="list-style-type: none"> 1) Some fault conditions warrant a 5 minute timeout, if the unit does not return to normal operation after 5 minutes contact technical service.
LCD Screen displays solid black or solid white	<ol style="list-style-type: none"> 1) Turn the unit off using the power switch on the bottom, wait 1 minute and turn it back on again.
Inverter display does not show connected REbus™ devices OR connected devices have status “offline” although the inverter is operating.	<ol style="list-style-type: none"> 1) Check that ground wire on REbus™ side is connected to the lug in the wiring compartment. There must be a continuous ground wire from the X3001 to the device for communications to work properly. 2) Reseat the cable that attaches the LCD screen to the main board within the X3001. Note this is a polarized connector. It may be dislodged during shipping or installation. 3) Call technical support for further troubleshooting.
Inverter shows devices that are no longer connected to REbus™	<ol style="list-style-type: none"> 1) Delete unwanted devices by selecting “Remove” under the device page. Reference X3001 Operations Manual for further detail.



35 Bradley Drive, #1
Westbrook ME 04092
info@pika-energy.com

pika-energy.com

