

SOLAR CARPORT SINGLE ROW

Ready-Made Shade Structures

Assembly Instructions

SAFETY CONSIDERATIONS

This application procedure is not intended to supersede any company construction or safety standards. This procedure is offered only to illustrate safe application for the individual. **FAILURE TO FOLLOW THESE PROCEDURES MAY RESULT IN PERSONAL INJURY OR DEATH.**

Do not modify this product under any circumstances, except where noted in this application procedure.

This product is intended for use by trained technicians only. **This product should not be used by anyone who is not familiar with, and not trained to use it.**

When working in the area of energized lines, extra care should be taken to prevent accidental electrical contact. Be sure to wear proper safety equipment per your company protocol.

Product Description

About the Product

PLP Carports are engineered and optimized to site-specific applications and PV solar installation. The modular structures feature a simplified design and integrated PV module mounting system, resulting in faster assembly rates and labor savings on every project. These solar support structures feature tilt angles that offer 0, 5, and 10 degree positions and an optional gasket sealing solution. PLP's unique module clamping system offers 50 percent fewer components than traditional systems and has built-in $\frac{3}{4}$ spacing. This system offers 4-high in portrait for 60- and 72- cell modules or 6 high for 72-cell or 7 high for 60-cell module mounting for a single row or double row car parking with built-in wire management channels.

Pre-Configured Components

For ease of assembly and to address the wide range of modules available, the Carport ships pre-configured to meet the dimensional requirements of the PV Modules.

For foundation and vertical recommendations on specific installation, please:

Contact us by phone: 800-260-3792

Send an email request: info@plpsolar.com

About These Instructions

- They include information on assembling the product and are intended to be used by

individuals with sufficient technical skills for the task. Knowledge and use of hand tools, measure devices and torque values is also required.

- They include various Notes, Cautions, and Warnings that are intended to draw your attention and assist in the assembly process and/or draw attention to the fact that certain assembly steps may be dangerous and could cause serious physical injury and/ or damage to components. Follow the procedures and precautions in these instructions carefully

Periodic Inspection

Periodic re-inspection is a recommended system maintenance procedure to check for any loose components and any corrosion. If any loose components or any corrosion is found, the affected components are required to be replaced immediately, with the original mounting system manufacturer's component parts.

Required Tools

- 1- $\frac{1}{4}$ socket for $\frac{3}{4}$ inch hardware
- 7/16 wrench and socket for 1/4 inch module clamp Hand Wrench
- Tape Measure
- Several 2x4s and a hand saw to create a spacing jig
- Pneumatic Impact Drill
- Torque Wrench
- Socket for 7/8" OS Nut

Table of Contents

Components

SOLAR CARPORT (0°, 5°, 10°) System 3-4

Installation

Step 1: Set Columns 5

Step 2: Installing the Strongback to the Column 5

Step 3: Placing Cee Purlins on Strongback..... 6

Step 4: Installing Cee Purlin Cantilever 7

Step 5: Installing Cee Purlin Splice 8

Step 6: Squaring the System 9

Step 7: Installing the Shared Module Clamp 10

Step 8: WEEB Lug and Wiring 11

Step 9: Installing Optional Carport Accessories 12

Components

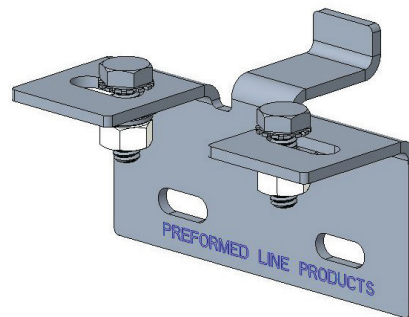
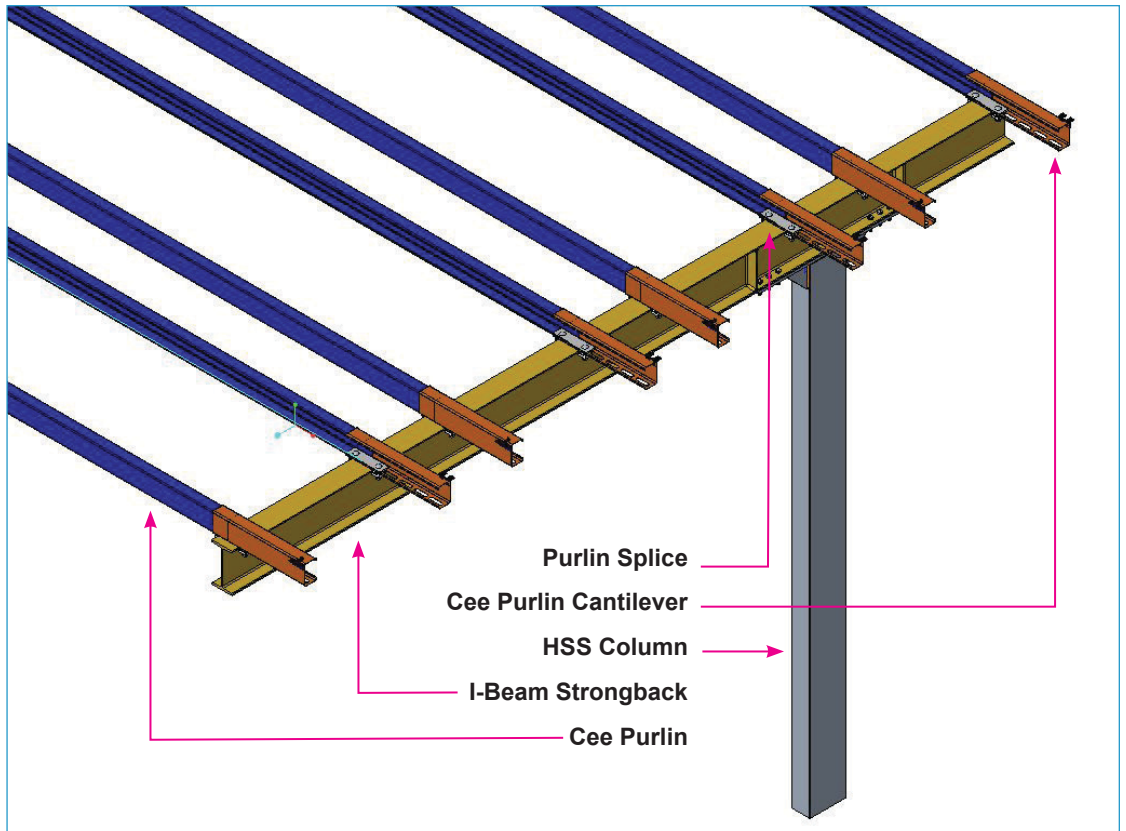

Shared Module Clamp

Components

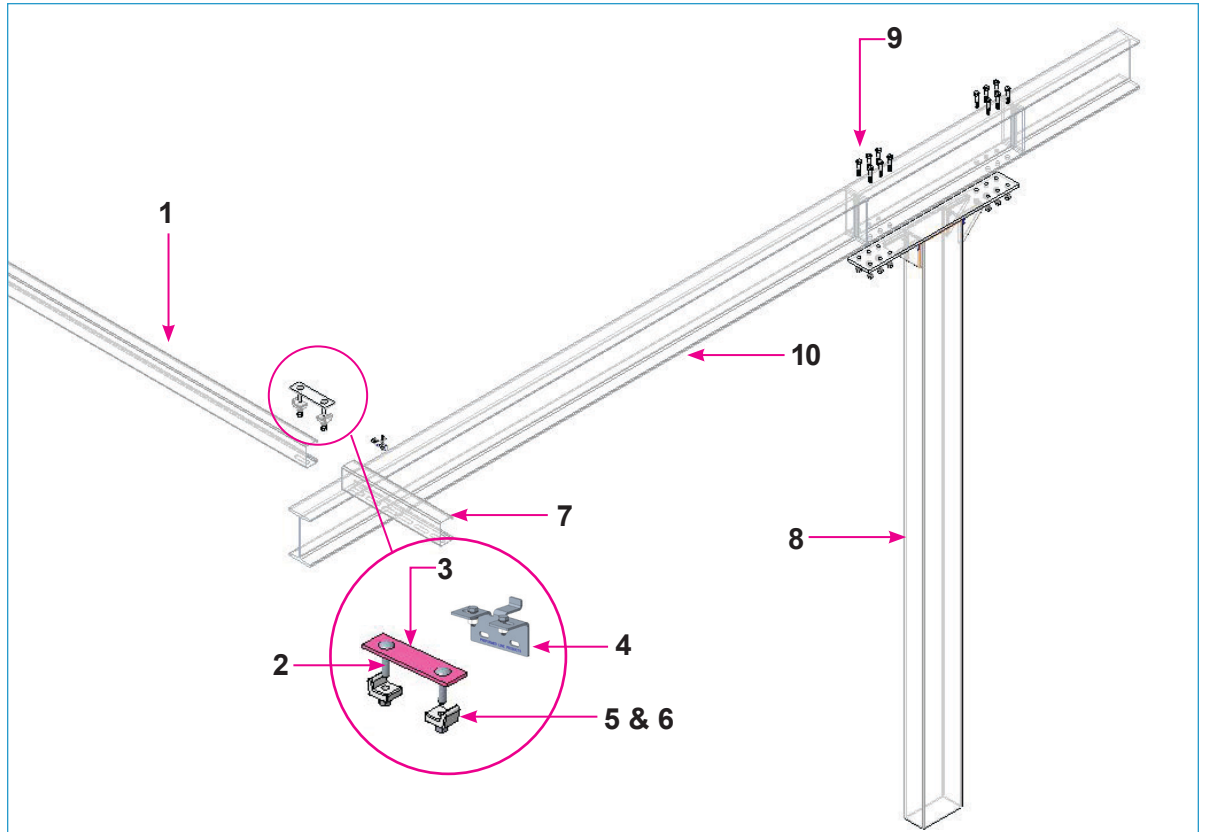

Item	Description
1	Cee Purlin
2	3/4" – 10 x 3 1/2" CAR Bolt, Galvanized
3	Purlin Splice
4	Shared Module Clamp
5	3/4" Lock Washer, Galvanized (also used at Strongback Column connection)
6	3/4" – 10, Oversized Nut, Galvanized (also used at Strongback Column connection)
7	Cee Purlin Cantilever, Galvanized
8	Column
9	3/4" – 10 x 2 1/2" Bolt, Galvanized
10	Strongback

Installation

Step 1: Set Columns

NOTE:

Leveling the nuts the column sits on so the tops are level will help keep things squared.

Using an augured foundation, set the HSS Column per the project specifications and drawings while keeping the relative height tolerance to each adjacent column at +/- 1". (Reference project drawings for foundation design and depth.)

Step 2: Installing the Strongback to the Column

NOTE:

Strongbacks must be consistently installed facing the same direction (i.e., long cantilever out towards parking spot).

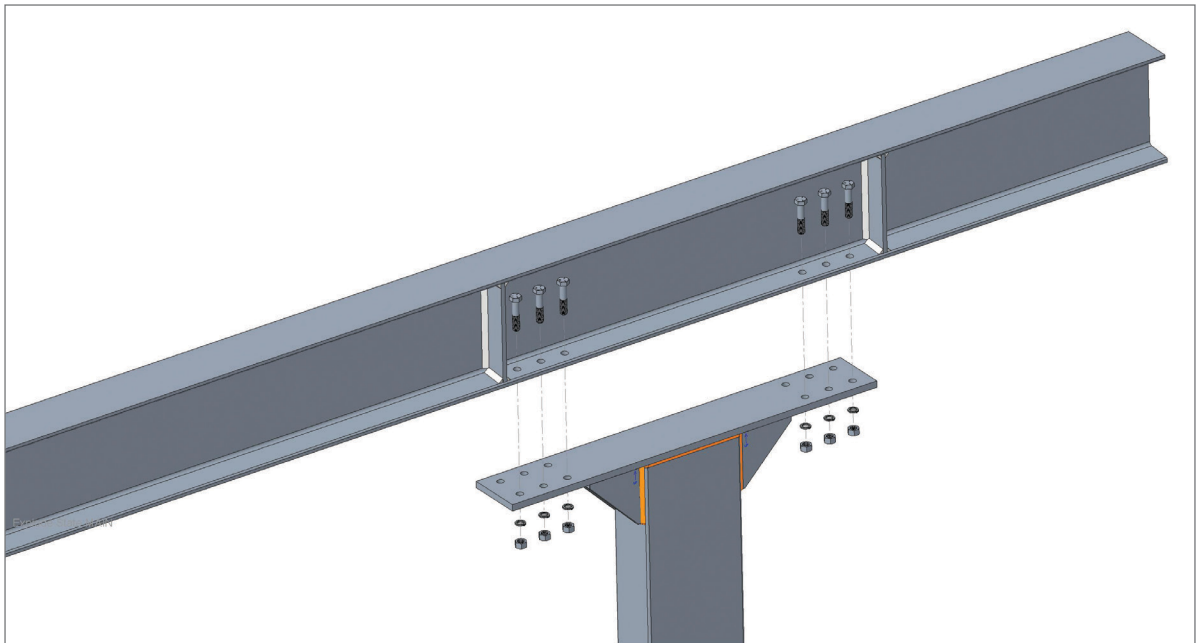

Install the bolts from the top down. The lock washer should be used between the nut and the plate. Fully torque bolts to 230 - 250 Ft-lbs.

*Need to verify that front edges of SB are 19' O.C. If they are not, use a ratchet strap or come along to bring the strongbacks to 19' O.C. and then install the first row of purlins to hold the strongbacks in place.

Installation

Step 3: Installing Cee Purlin Cantilever

NOTE:

Cee Purlin Cantilever is over sized, so it easily slides over the Cee Purlin.

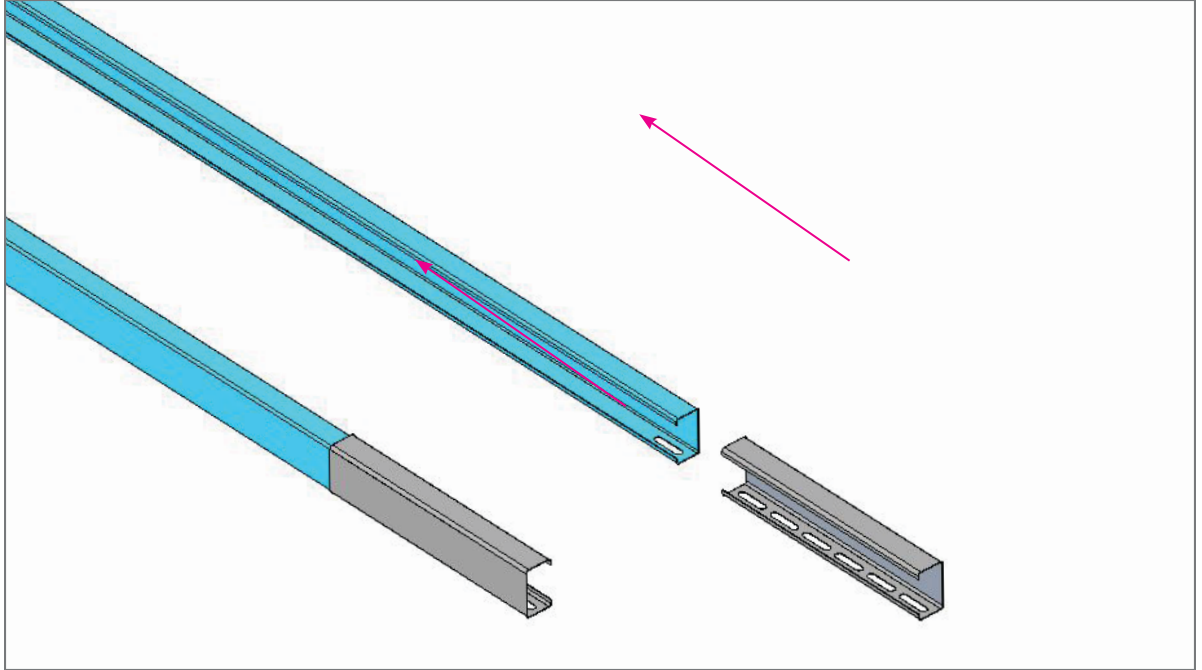

The Cee Purlin Cantilever is to be installed to accommodate module over hang. Check the plan drawings to determine how far to extend cantilever. Can be adjusted while resting on strongback.

The Cee Purlin Cantilever will slide over the ends of the purlins at the end of each sub array.

This should be done on the ground for the outside bays. It is easier than sliding them on in the air.

Installation

Step 4: Placing Cee Purlins on Strongback

NOTE:

Two jigs should be used for the two different rail spacings. Jigs should be measured to within 1/16 inches of dimension on drawing. Check plan drawings for dimensions.

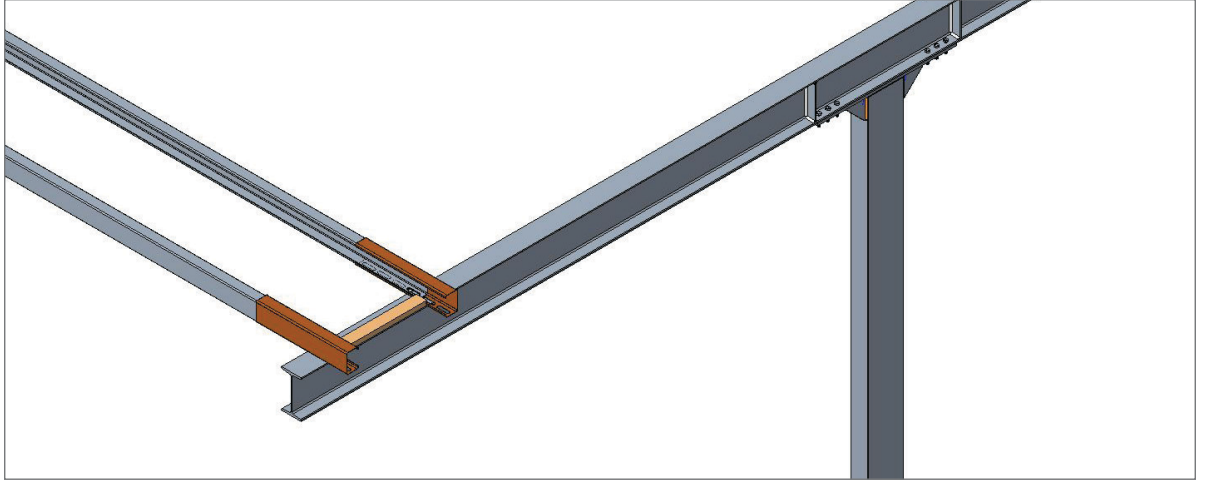

Place the first rail X (where X = amount of inches) from the end of the Strongback. Refer to the construction drawing provided. Measure from the outside flat web of the Cee purlin (Use tape measure).

The end of each rail should rest in the centerline of the Strongback. Cee Purlins are to change orientation along the Strongback.

NOTE:

Jigs for the outer strongbacks are a different length than the interior. Please reference construction drawings.

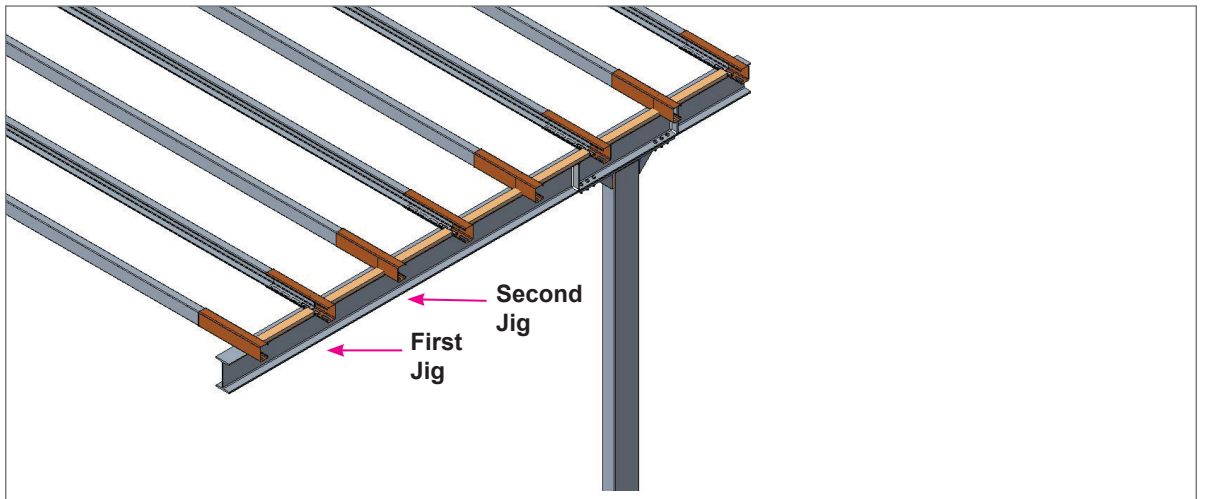

From there, a jig should be used to set the spacing between the rails. Two different sized jigs will be needed and can be as simple as a 2x4 that is cut to length (See Note).

First jig should be placed from the bent Cee to bent Cee.

Second jig should be placed from the outside flat web to outside flat web. Continue by alternating jigs until all purlins are placed.

Have enough jigs for several bays.

Installation

Step 5: Installing Purlin Splice

NOTE:

Make sure that the Cee Purlin Splice is hand tightened to prevent movement when working across the bays.

NOTE:

Flat bar splice should be used on exterior strongholds with snow loads equal to or greater than 15 psf snow load L-Shape should be used on all internal strongbacks at those loads. Flat bar can be used throughout system with snow loads under 15 psf.

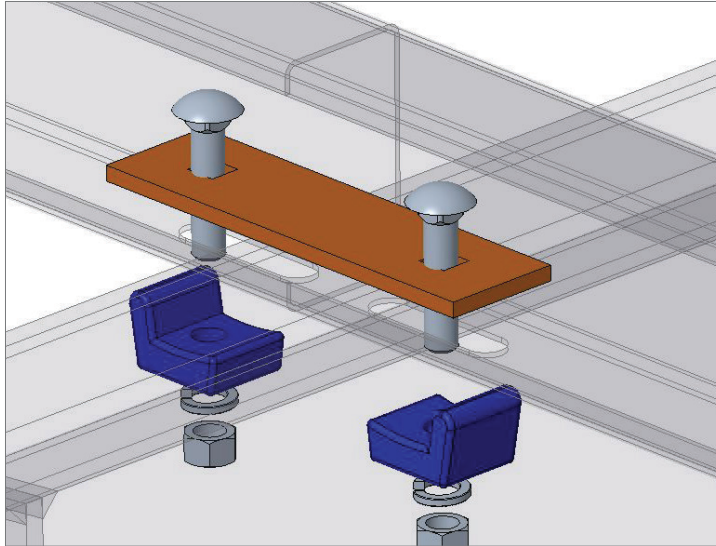

The Purlin Splice is placed in the slot of the Cee Purlin with the holes lining up to the slots on the purlins.

Hand tighten and make sure the attachment is square. Adjust slightly as needed.

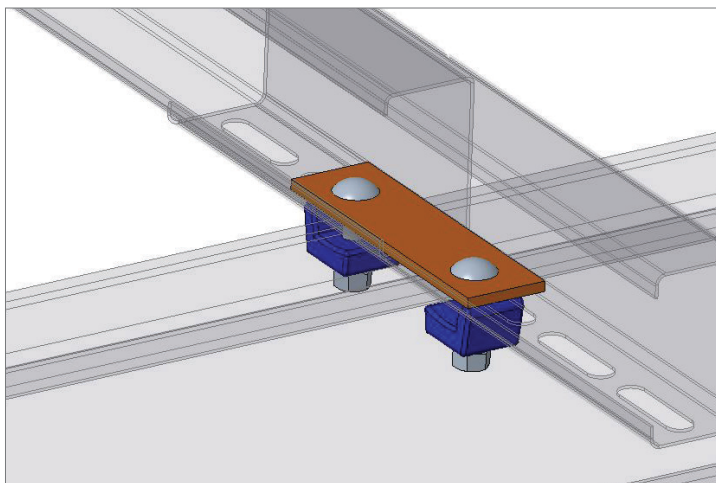

The Cee Purlin Splice is installed in the same way for the Cee Cantilever on the ends. Project drawings will show how far the Cee Cantilever extends out past Strongback.

The hardware is installed with bolt, clamp, lock washer, and nut. No flat washer is required.

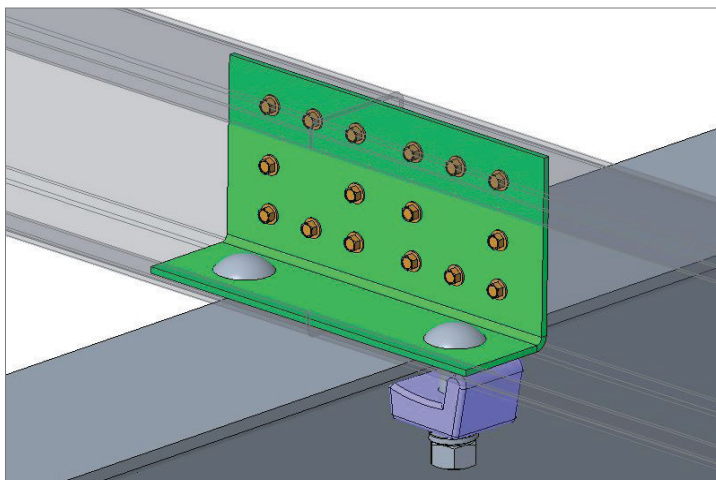

Self tapping screws need to be installed in each hole on L-shaped splice. Hardware install is the same as the flat bar (bolt, clamp, lock washer, and nut).

Installation

Step 6: Squaring the System

NOTE:

It would be beneficial to have several spacing jigs to help speed up installation.

NOTE:

Use spacing jigs to hold purlins in place while torquing down splice hardware. Can be removed after tightening.



Make sure that the Cee Purlins are square across each bay before installing the modules and tightening hardware. With the Cee Purlin Splice being hand tightened, the Cee Purlins can be adjusted to ensure that the table is square. Continue using jigs to make sure each new bay is squared.

Cee Purlin Splice hardware needs to be tightened to 210 ft-lbs.

Installation

Step 7: Installing the Shared Module Clamp

NOTE:

Star washer must be installed between bolt head and module frame for proper grounding. Extra washers will be provided.

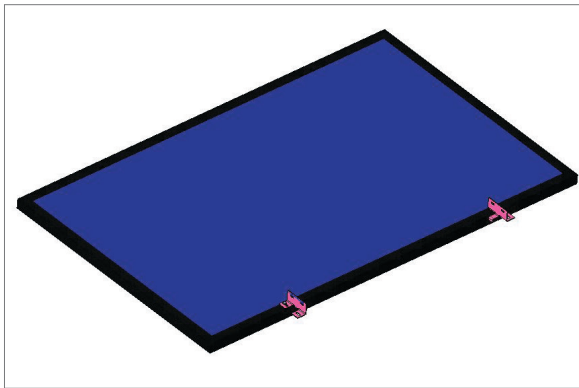
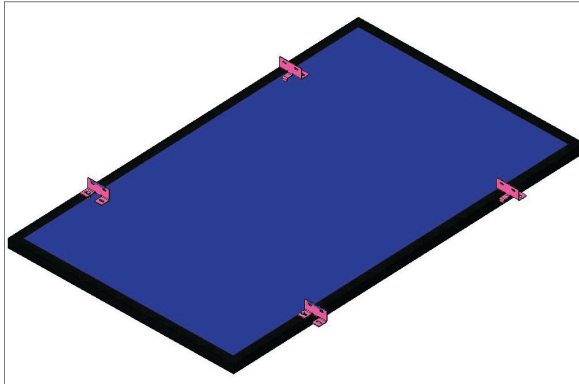

Install module clamps onto the modules before putting modules on the purlins. Make sure the flats face each other.

The first outside row needs 4 clamps. Two on the edge sit inboard of module every one after sits outboard.

When installing modules along a row, butt the frame up to the bent portion for correct spacing.

Hardware is tightened down to 4 – 6 ft-lbs.

The Shared Module Clamp uses self-tapping screws to drill directly into the Cee Purlin. Spacing is determined by the horizontal hole to hole dimension on the module.

The bolts are installed top down through the module frame hole locations.

Refer to the construction drawings for module spacing.

NOTE:

Module Clamps on the end of continuous bays will sit inside the module like the image shows.

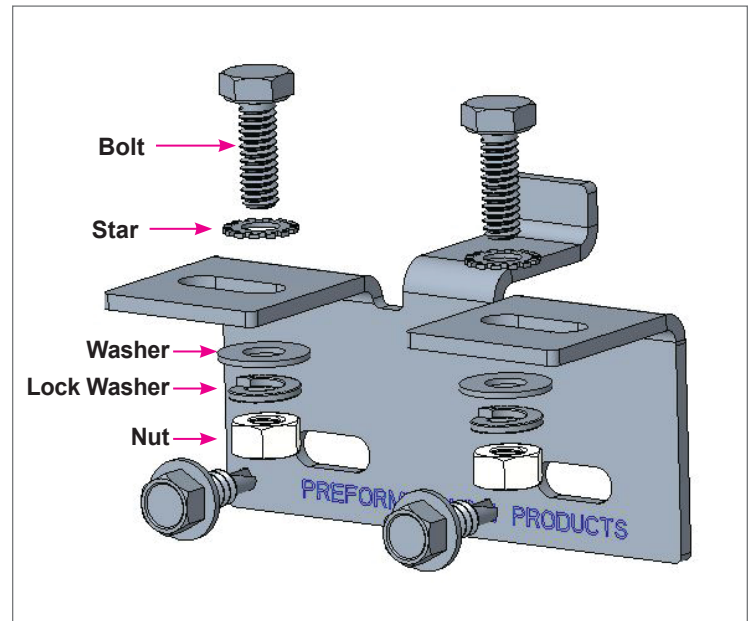
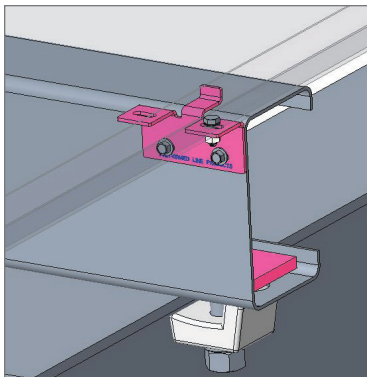

Installation

Step 8: WEEB Lug and Wiring

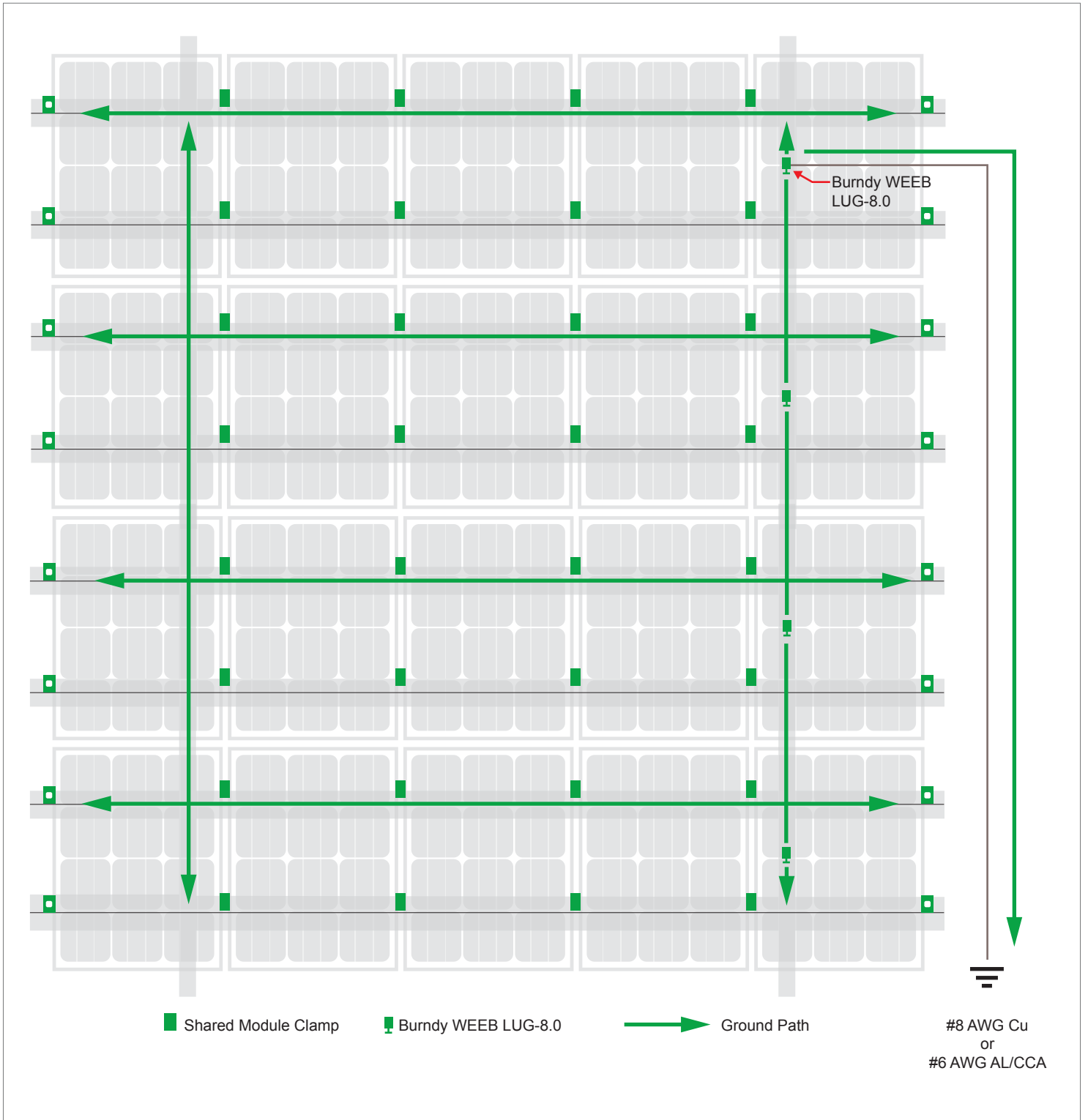

Installation

Step 9: Installing Optional Carport Accessories

Cable management accessories, microinverters, optimizers, signs, lighting fixtures, and other equipment may be attached directly to PLP Carports per the following guidelines.

Attachments and Cable Routing

- Drilling self-tapping screws along the Cee Purlin to attach cable management accessories and equipment is acceptable.
- Holes may be drilled in the centerline of the 6" face of the Cee Purlins. Maximum hole size is 1" diameter.
- Holes may not be drilled in Cee Purlins within 2.5ft of the I-Beam strongback and within the middle 5ft section of the span. Reference diagram

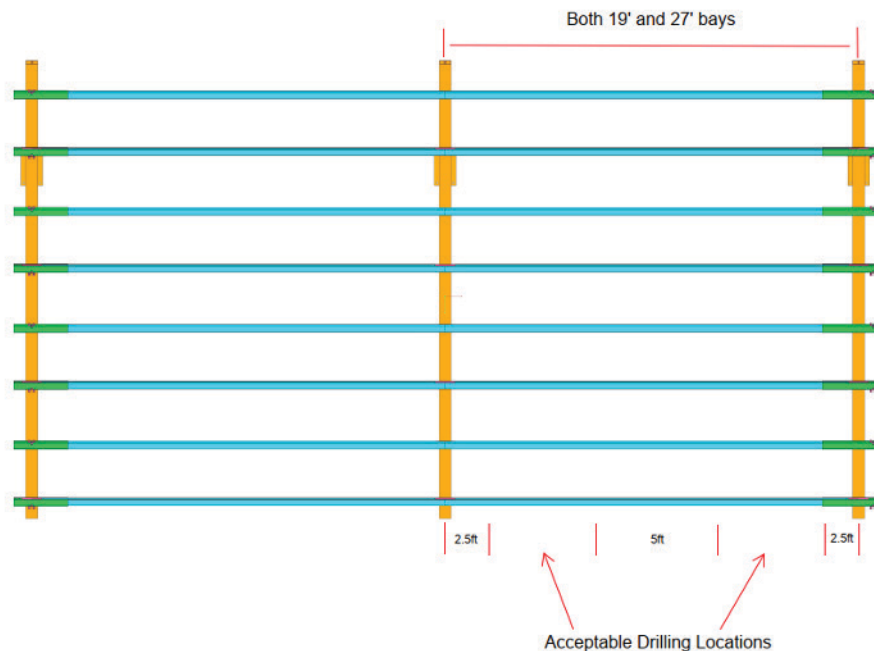

- If multiple holes are required in a Cee Purlin, the holes must be a minimum 3ft apart with a maximum of two holes in the space allowed for drilling.
- Holes may be drilled near the top of the HSS Column to route cable down through the HSS tube. Maximum hole size is 1" diameter and located in the vertical centerline of the HSS Column faces.
- Note: Holes are included in the base of the HSS Column for cable routing.

Equipment Weight Limits

- The maximum weight of all equipment attached to a Cee Purlin including lighting fixtures, signs, and other accessories is 50 lbs. per Cee Purlin.
- The maximum weight limit of all equipment attached to the HSS Column is 200 lbs.



Global Headquarters
660 Beta Drive
Mayfield Village, OH 44143

Telephone: 800.260.3792
Fax: 440.442.8816
preformed.com
Email: info@plpsolar.com